



T O O L I N G

M I L L I N G





Frese per spianatura - spallamenti (90°)

Planfräseser - eckfräseser (90°)

Face - shoulder milling cutters (90°)

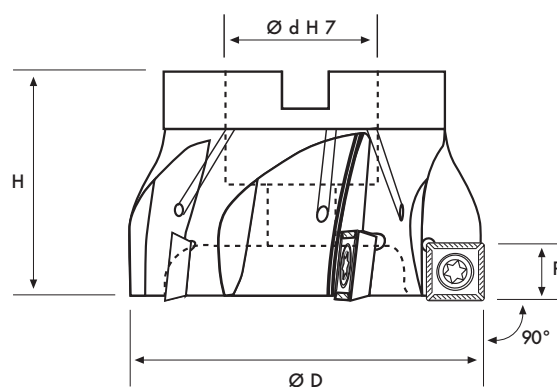
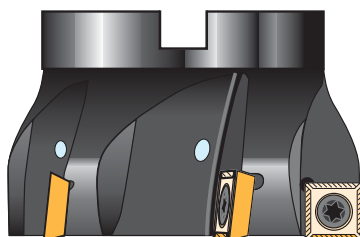
ART. **710 M**



Codice d'ordine Bestell-Nr Order No.	(mm) Dimensioni - Abmessungen - Dimensions										Inserto Wendepatte Insert	Ricambi - Ersatzteile Spare parts	
	D	De	dH7	c	e	a	b	H	p	z		Vite - Screw	Chiave - Key
710M-W-D50	50		22					40	10,5	5	SDMT 1205	VT 40710 	CT 15 
710M-W-D63	63		22					40	10,5	6			
710M-W-D80	80		27					50	10,5	6			
710M-W-D100	100		32					50	10,5	8			
710M-W-D125	125		40					63	10,5	9			

Inserto
Wendepatte
Insert

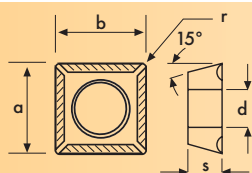

SDMT 1205	a	b	s	d	r
	12,7	12,7	5,0	4,4	0,8

M-W= Con foro refrigerante - Kuehlmittelbohrung - Coolant bores

Frese per spallamenti

Eckfraeser

Shoulder milling cutters

ART. 730 W

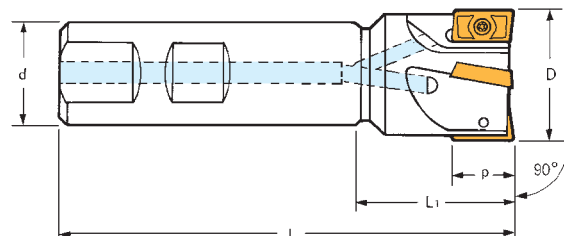
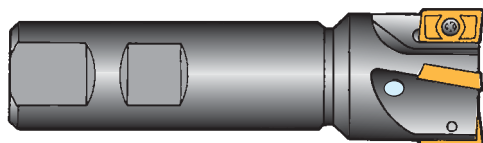

NOVITÀ
NEU
NEW

Codice d'ordine Bestell-Nr Order No.	(mm) Dimensioni - Abmessungen - Dimensions						Inserto Wendeplatte Insert	Ricambi - Ersatzteile Spare parts	
	D	d	L	L1	p	z		Vite - Screw	Chiave - Key
730W-D25	25	25	100	44	17	2	APFT APKT APHT 1604 ...	VT 40	CT 15
730W-D32	32	32	110	50	17	3			
730W-D40	40	32	115	45	17	4			
730W-W-D25	25	25	100	44	17	2			
730W-W-D32	32	32	110	50	17	3			
730W-W-D40	40	32	115	45	17	4			
730W-WL-D22	22	20	200	60	17	2			
730W-WL-D25	25	25	200	60	17	2			
730W-WL-D32	32	32	200	60	17	3			
730W-WL-D40	40	32	200	60	17	4			

ART. 730 M

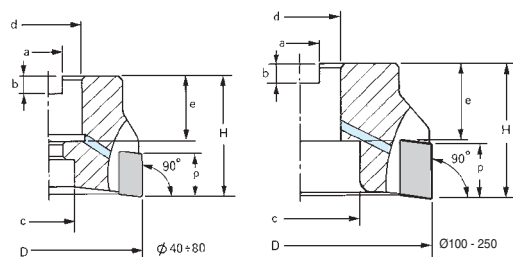
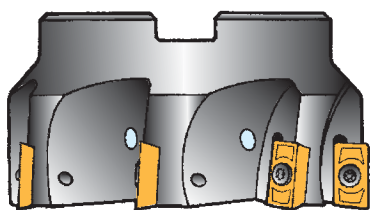

NOVITÀ
NEU
NEW

Codice d'ordine Bestell-Nr Order No.	(mm) Dimensioni - Abmessungen - Dimensions									Inserto Wendeplatte Insert	Ricambi - Ersatzteile Spare parts	
	D	d	c	e	a	b	H	p	z		Vite - Screw	Chiave - Key
730M-D40	40	16	12	18	8,4	5,6	40	17	4	APFT APKT APHT 1604 ...	VT 40	CT 15
730M-D50	50	22	18	21	10,4	6,3	40	17	5			
730M-D63	63	22	18	21	10,4	6,3	40	17	6			
730M-D80	80	27	20	22	12,4	7	50	17	7			
730M-D100	100	32	45	26	14,4	8	50	17	8			
730M-D125	125	40	56	38	16,4	9	63	17	9			
730M-D160	160	40	87	32	16,4	9	63	17	10			
730M-D200	200	60	-	32	16,4	9	63	17	13			
730M-D250	250	60	-	32	16,4	9	63	17	16			
730M-W-D40	40	16	12	8	8,4	5,6	40	17	4			
730M-W-D50	50	22	18	21	10,4	6,3	40	17	5			
730M-W-D63	63	22	18	21	10,4	6,3	40	17	6			
730M-W-D80	80	27	20	22	12,4	7	50	17	7			
730M-W-D100	100	32	45	26	14,4	8	50	17	8			
730M-W-D125	125	40	56	38	16,4	9	63	17	9			

W-W e M-W= Con foro refrigerante - Kuehlmittelbohrung - Coolant bores

Frese per spallamenti

Eckfraeser

Shoulder milling cutters

ART. 740 W

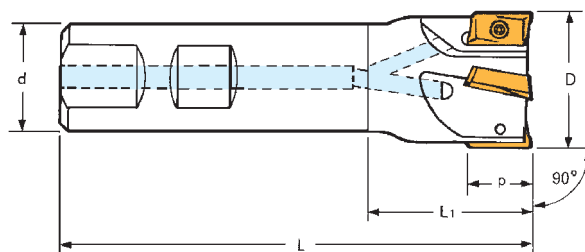
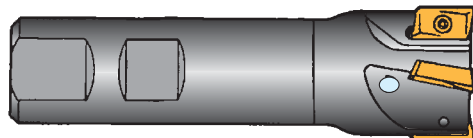

NOVITÀ
NEU
NEW

Codice d'ordine Bestell-Nr Order No.	(mm) Dimensioni - Abmessungen - Dimensions						Inserto Wendepatte Insert	Ricambi - Ersatzteile Spare parts	
	D	d	L	L1	p	z		Vite - Screw	Chiave - Key
740W-W-D10	10	16	80	24	10	1	APHT APHX APKT 1003 ...	VT 25	BT 08
740W-W-D12	12	16	80	24	10	1			
740W-W-D14	14	16	80	24	10	1			
740W-W-D15	15	16	85	25	10	2			
740W-W-D15,7	15,7	16	85	25	10	2			
740W-W-D16	16	16	85	25	10	2			
740W-W-D17	17	16	85	25	10	2			
740W-W-D18	18	20	85	25	10	2			
740W-W-D19,7	19,7	20	90	25	10	3			
740W-W-D20	20	20	90	25	10	3			
740W-W-D22	22	25	95	25	10	3			
740W-W-D24,7	24,7	25	95	25	10	3			
740W-W-D25/3	25	25	95	25	10	3			
740W-W-D25/4	25	25	95	25	10	4			
740W-W-D28	28	25	95	25	10	4			
740W-W-D30	30	25	95	25	10	4			
740W-W-D32	32	25	95	26	10	5			
740W-WL-D10	10	16	150	24	10	1			
740W-WL-D12	12	16	150	24	10	1			
740W-WL-D16	16	16	150	24	10	2			
740W-WL-D20	20	20	150	25	10	3			
740W-WL-D25	25	20	150	25	10	4			
740W-WL-D32	32	25	150	26	10	5			

ART. 740 M

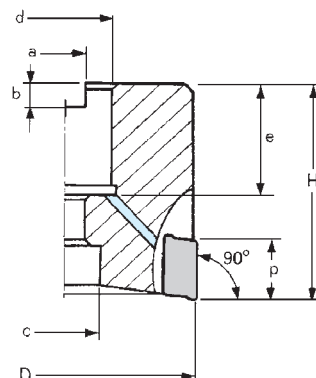

Codice d'ordine Bestell-Nr Order No.	(mm) Dimensioni - Abmessungen - Dimensions									Inserto Wendepatte Insert	Ricambi - Ersatzteile Spare parts	
	D	d	c	e	a	b	H	p	z		Vite - Screw	Chiave - Key
740M-W-D40	40	22	17	21	10,4	6,3	40	10	6	APHT APHX APKT 1003 ...	VT 25	BT 08
740M-W-D50	50	22	17	21	10,4	6,3	40	10	7			
740M-W-D63	63	22	17	21	10,4	6,3	40	10	8			
740M-W-D80	80	27	20	22	12,4	7	50	10	11			
740M-W-D100	100	32	26	26	14,4	8	50	10	12			

W-W e M-W= Con foro refrigerante - Kuehlmittelbohrung - Coolant bores



Frese per spallamenti

Eckfraeser

Shoulder milling cutters

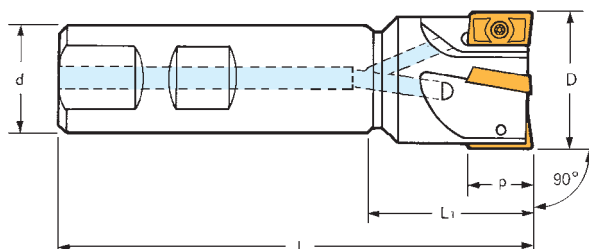
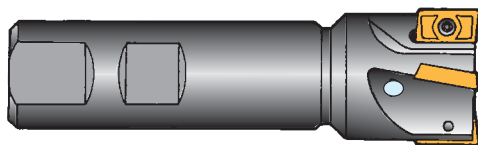
ART. 790 W



Codice d'ordine Bestell-Nr Order No.	(mm) Dimensioni - Abmessungen - Dimensions						Inserto Wendeplatte Insert	Ricambi - Ersatzteile Spare parts	
	D	d	L	L1	p	z		Vite - Screw	Chiave - Key
790W-W-D25	25	25	100	35	13,5	2	ADKT ADKR ADMM ADMT 1505 ...	VT 40	CT 15
790W-W-D32	32	32	110	40	13,5	3			
790W-W-D40	40	32	115	40	13,5	4			

ART. 790 M

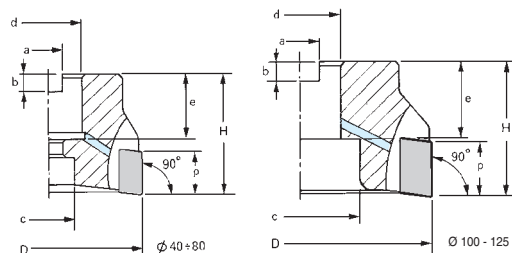
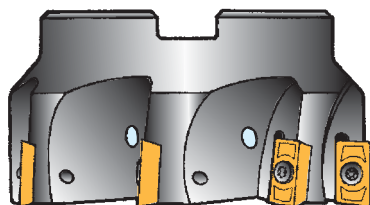

Codice d'ordine Bestell-Nr Order No.	(mm) Dimensioni - Abmessungen - Dimensions									Inserto Wendeplatte Insert	Ricambi - Ersatzteile Spare parts	
	D	d	c	e	a	b	H	p	z		Vite - Screw	Chiave - Key
790M-W-D40	40	16	12	18	8,4	5,6	40	13,5	4	ADKT ADKR ADMM ADMT 1505 ...	VT 40	CT 15
790M-W-D50	50	22	17	21	10,4	6,3	40	13,5	5			
790M-W-D63	63	22	17	21	10,4	6,3	40	13,5	6			
790M-W-D80	80	27	20	22	12,4	7	50	13,5	7			
790M-W-D100	100	32	45	26	14,4	8	50	13,5	8			
790M-W-D125	125	40	56	38	16,4	9	63	13,5	9			

W-W e M-W= Con foro refrigerante - Kuehlmittelbohrung - Coolant bores

Frese per spianatura (45°)

Planfraeser (45°)

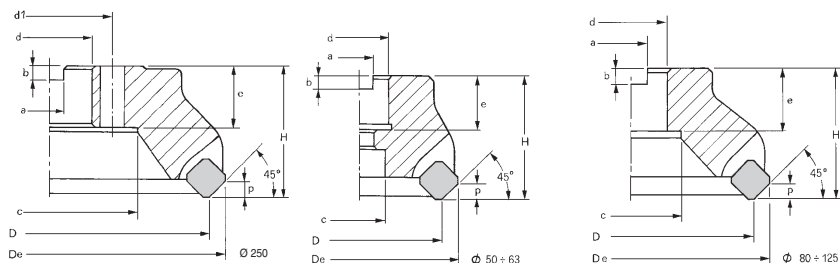

Face milling cutters (45°)

ART. 550 M



Codice d'ordine Bestell-Nr Order No.	(mm) Dimensioni - Abmessungen - Dimensions											Inserto Wendeplatte Insert
	D	De	d	d1	c	e	a	b	H	p	z	
550M-D50-12	50	63	22	-	17	21	10,4	6,3	48	6	4	SEKN SEKR SEAN 1203...
550M-D63-12	63	76	22	-	19	21	10,4	6,3	40	6	5	
550M-D80-12	80	93	27	-	38	24	12,4	7	50	6	6	
550M-D100-12	100	113	32	-	45	26	14,4	8	50	6	6	
550M-D125-12	125	138	40	-	56	32	16,4	9	63	6	7	
550M-D160-12	160	173	40	66,7	86	32	16,4	9	63	6	7	
550M-D200-12	200	213	60	101,7	129	32	25,7	14	63	6	10	
550M-D250-12	250	263	60	101,7	178	32	25,7	14	63	6	13	

Ricambi - Ersatzteile - Spare parts



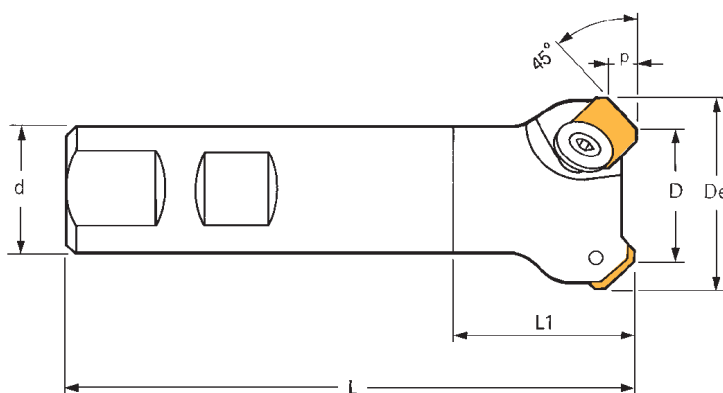
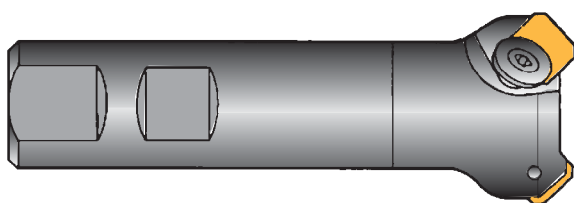

Sottoplacchetta Support	Vite di bloccaggio Insert locking screw	Vite sottoplacchetta Screw support	Chiave Key	Chiave Key
				
AKE 12,4	CVB 55	VF 4	CL 2	ET 4

ART. 550 W



Codice d'ordine Bestell-Nr Order No.	(mm) Dimensioni - Abmessungen - Dimensions								Inserto Wendeplatte Insert
	D	De	d	L	L1	p	z		
550W-D25-12	25	38	25	100	35	6	2	SEKN SEKR SEAN 1203...	
550W-D32-12	32	45	25	110	44	6	3		
550W-D40-12	40	53	32	115	45	6	4		

Ricambi - Ersatzteile - Spare parts

Sottoplacchetta Support	Vite di bloccaggio Insert locking screw	Vite sottoplacchetta Screw support	Chiave Key	Chiave Key
				
AKE 12,4	CVB 55 -C	VF 4	CL 2	ET 4

Frese per spianatura (45°)

Planfräser (45°)

Face milling cutters (45°)

ART. 600 M

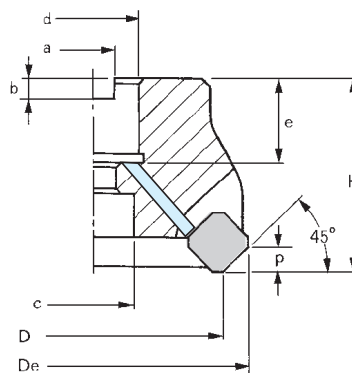
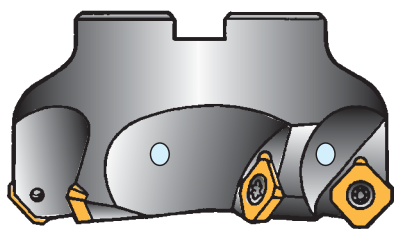

NOVITÀ
NEU
NEW

Codice d'ordine Bestell-Nr Order No.	(mm) Dimensioni - Abmessungen - Dimensions										Inserto Wendeplatte Insert	Ricambi - Ersatzteile Spare parts	
	D	De	d	c	e	a	b	H	p	z		Vite - Screw	Chiave - Key
600M-W-D40-12	40	53	16	14	18	8,4	5,6	40	6	3	SEHW SEHX SEHT 1204 ...	VT 50	CT 20
600M-W-D50-12	50	63	22	17	21	10,4	6,3	48	6	4		VT 50	CT 20
600M-W-D63-12	63	76	22	19	21	10,4	6,3	48	6	5		VT 50	CT 20
600M-W-D80-12	80	93	27	38	24	12,4	7	50	6	6		VT 50	CT 20
600M-W-D100-12	100	113	32	45	26	14,4	8	50	6	6		VT 50	CT 20
600M-W-D125-12	125	138	40	56	32	16,4	9	63	6	7		VT 50	CT 20
600M-W-D160-12	160	173	40	-	-	-	9	63	6	8		VT 50	CT 20
600M-D200-12	200	213	60	-	-	-	13,5	63	6	12		VT 50	CT 20
600M-D250-12	250	263	60	-	-	-	13,5	63	6	16		VT 50	CT 20
600M-W-D40-12 F	40	53	16	14	18	8,4	5,6	40	6	4		VT 50	CT 20
600M-W-D50-12 F	50	63	22	17	21	10,4	6,3	48	6	5		VT 50	CT 20
600M-W-D63-12 F	63	76	22	19	21	10,4	6,3	48	6	6		VT 50	CT 20
600M-W-D80-12 F	80	93	27	38	24	12,4	7	50	6	7		VT 50	CT 20
600M-W-D100-12 F	100	113	32	45	26	14,4	8	50	6	8	VT 50	CT 20	
600M-W-D125-12 F	125	138	40	56	32	16,4	9	63	6	10	VT 50	CT 20	
600M-W-D160-12 F	160	173	40	-	-	-	9	63	6	12	VT 50	CT 20	

ART. 600 W

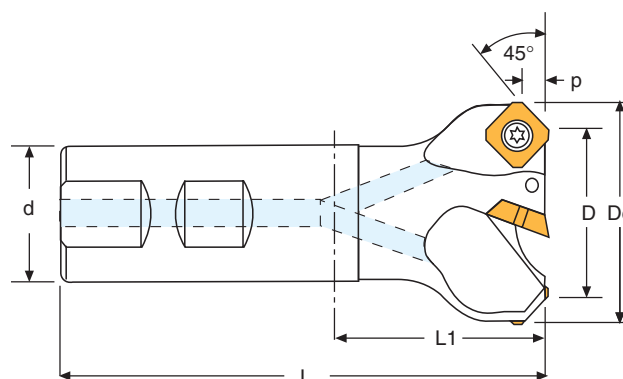
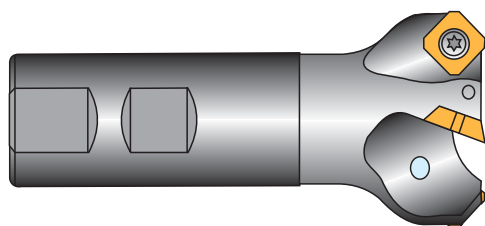

Codice d'ordine Bestell-Nr Order No.	(mm) Dimensioni - Abmessungen - Dimensions							Inserto Wendeplatte Insert	Ricambi - Ersatzteile Spare parts	
	D	De	d	L	L1	p	z		Vite - Screw	Chiave - Key
600W-W-D25	25	38	25	100	44	6	2	SEHW SEHX SEHT 1204...	VT 50	CT 20
600W-W-D32	32	45	25	110	54	6	3		VT 50	CT 20
600W-W-D40	40	53	32	115	55	6	4		VT 50	CT 20

W-W e M-W= Con foro refrigerante - Kuehlmittelbohrung - Coolant bores

Frese per spianatura (45°)



Planfraäser (45°)

Face milling cutters (45°)

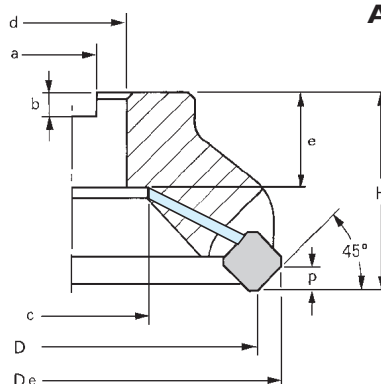
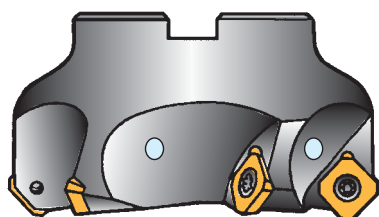
ART. 670 M



NOVITÀ
NEU
NEW

Codice d'ordine Bestell-Nr Order No.	(mm) Dimensioni - Abmessungen - Dimensions										Inserto Wendeplatte Insert	Ricambi - Ersatzteile Spare parts	
	D	De	d	c	e	a	b	H	p	z		Vite - Screw	Chiave - Key
670M-W-D50-12	50	63	22	17	21	10,4	6,3	48	6	4	SDHT SDHW SDMT 1204 ...	VT 45 P 	CT 20 
670M-W-D63-12	63	76	22	19	21	10,4	6,3	48	6	5			
670M-W-D80-12	80	93	27	38	24	12,4	7	50	6	6			
670M-W-D100-12	100	113	32	45	26	14,4	8	50	6	6			
670M-W-D125-12	125	138	40	56	32	16,4	9	63	6	7			
670M-W-D160-12	160	173	40	-	-	-	9	63	6	8			
670M-D200-12	200	213	60	-	-	-	13,5	63	6	12			
670M-D250-12	250	263	60	-	-	-	13,5	63	6	16			

W-W e M-W= Con foro refrigerante - Kuehlmittelbohrung - Coolant bores

Frese per spianatura (75°)

Planfraäser (75°)



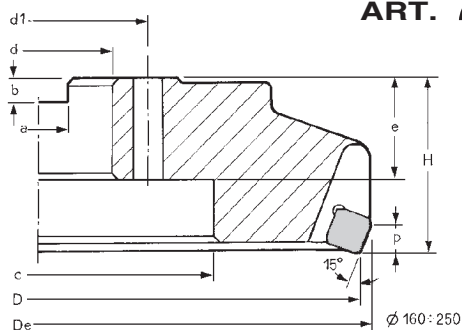

Face milling cutters (75°)

ART. 750 M



Codice d'ordine Bestell-Nr Order No.	(mm) dimensioni - Abmessungen - Dimensions											Inserto Wendeplatte Insert
	D	De	d	d1	c	e	a	b	H	p	z	
750M-D63	63	69	22	-	17	21	10,4	6,3	40	9	4	SPKN SPKR SPUN 1203 ...
750M-D80	80	86	27	-	19	23	12,4	7	50	9	5	
750M-D100	100	106	32	-	26	25	14,4	8	50	9	7	
750M-D125	125	131	40	-	56	32	16,4	9	63	9	8	
750M-D160	160	166	40	66,7	87	32	16,4	9	63	9	10	
750M-D200	200	206	60	101,7	129	32	25,7	14	63	9	12	
750M-D250	250	256	60	101,7	178	32	25,7	14	63	9	14	

Ricambi - Ersatzteile - Spare parts

Sottopiacchetta Support  AKP 12,4	Vite di bloccaggio Insert locking screw  CVB 55	Vite sottopiacchetta Screw support  VF 4	Chiave Key  CL 2	Chiave Key  ET 4
--	--	---	---	---

Frese per spianatura (75°)

Planfraeser (75°)

Face milling cutters (75°)

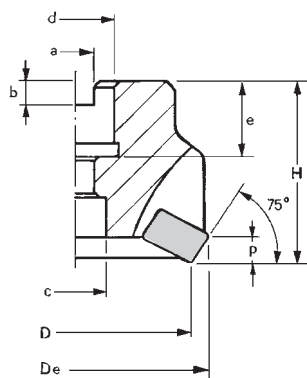
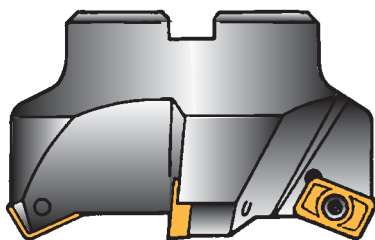

ART. 760 M

Codice d'ordine Bestell-Nr Order No.	(mm) Dimensioni - Abmessungen - Dimensions										Inserto Wendeplatte Insert	Ricambi - Ersatzteile Spare parts	
	D	De	d	c	e	a	b	H	p	z		Vite - Screw	Chiave - Key
760M-D50	50	54	16	14	21	8,4	5,6	40	6,5	3	APFT APKT APHT 1604 ...	VT 40 	CT 15
760M-D63	63	67	22	17	21	10,4	6,3	40	6,5	4			
760M-D80	80	84	27	20	22	12,4	7	50	6,5	5			
760M-D100	100	104	32	45	26	14,4	8	50	6,5	6			
760M-D125	125	129	40	56	32	16,4	9	63	6,5	7			

Inserto
Wendeplatte
Insert

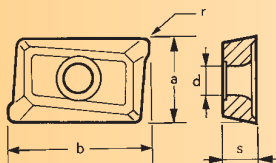

	a	b	s	d	r
APKT 1604... APFT 1604... APHT 1604... APHX 1604...	9,52	17	4,76	4,4	0,8

ART. 780 M

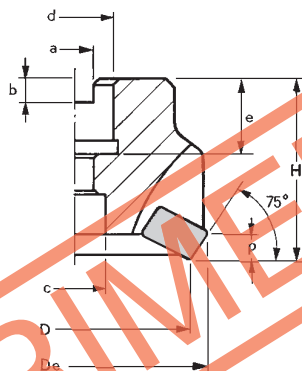
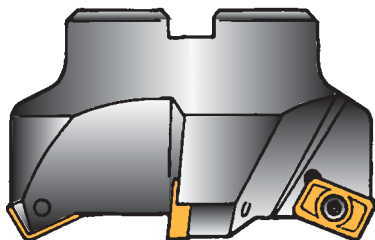

Codice d'ordine Bestell-Nr Order No.	(mm) Dimensioni - Abmessungen - Dimensions										Inserto Wendeplatte Insert	Ricambi - Ersatzteile Spare parts	
	D	De	d	c	e	a	b	H	p	z		Vite - Screw	Chiave - Key
780M-D50	50	54	16	14	21	8,4	5,6	40	6,5	3	ADKT ADKR ADMM ADMT 1505...	VT 40 	CT 15
780M-D63	63	67	22	17	21	10,4	6,3	40	6,5	4			
780M-D80	80	84	27	20	22	12,4	7	50	6,5	5			
780M-D100	100	104	32	45	26	14,4	8	50	6,5	6			
780M-D125	125	129	40	56	32	16,4	9	63	6,5	7			

Inserto
Wendeplatte
Insert

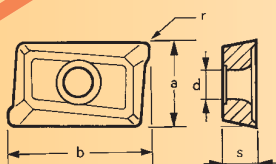



	a	b	s	d	r
ADKT 1505... ADKR 1505... ADMM 1505... ADMT 1505...	9,52	15,0	5,0	4,5	0,8

Frese per spianatura (75°)

Planfraeser (75°)
Face milling cutters (75°)

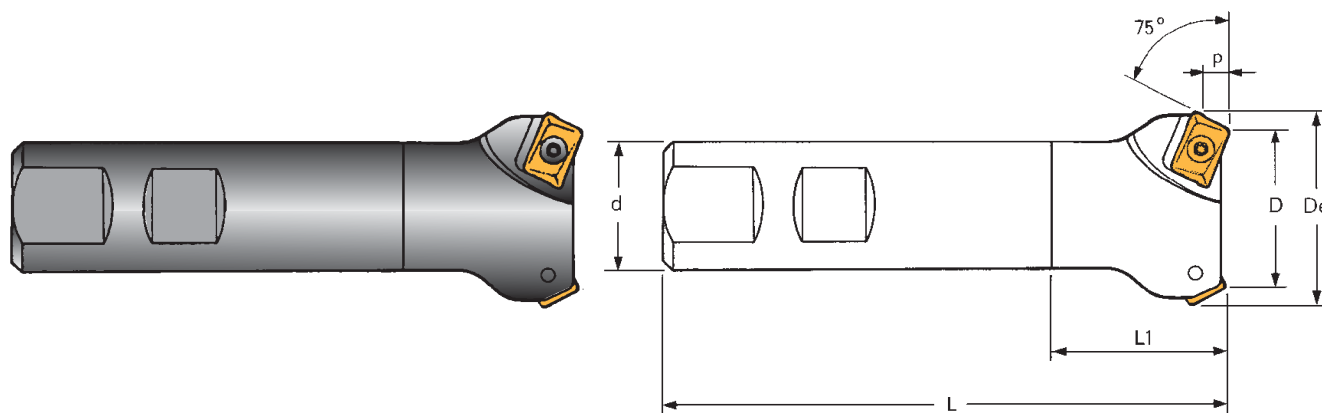

ART. 770 W

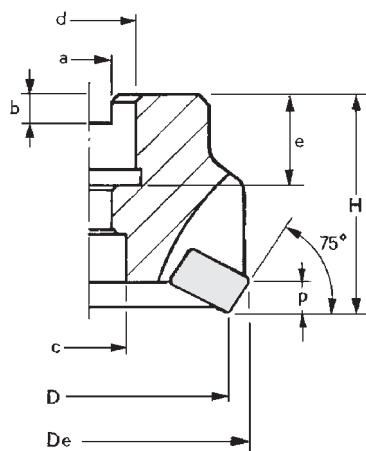
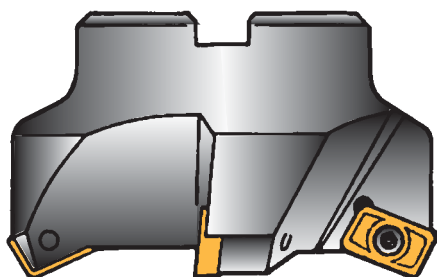

Codice d'ordine Bestell-Nr Order No.	(mm) Dimensioni - Abmessungen - Dimensions							Inserto Wendeplatte Insert	Ricambi - Ersatzteile Spare parts	
	D	De	d	L	L1	p	z		Vite - Screw	Chiave - Key
770W-D25	25	28,6	20	95	25	4	2	APHT APHX APKT 1003 ...	VT 25	BT 08
770W-D32	32	35,6	25	95	25	4	3			
770W-D40	40	43,6	25	100	25	4	4			

ART. 770 M



Codice d'ordine Bestell-Nr Order No.	(mm) Dimensioni - Abmessungen - Dimensions										Inserto Wendeplatte Insert	Ricambi - Ersatzteile Spare parts	
	D	De	d	c	e	a	b	H	p	z		Vite - Screw	Chiave - Key
770M-D50	50	54	22	17	21	10,4	6,3	40	6,5	5	APHT - APHX APKT 1003 ...	VT 25	BT 08
770M-D63	63	67	22	17	21	10,4	6,3	40	6,5	6			

Inserto
Wendeplatte
Insert

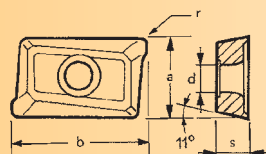

	a	b	s	d	r
APKT 1003... APHT 1003... APHX 1003...	6,7	10,8	3,55	2,8	0,5



Frese per spianatura (43°)

Planfraeser (43°)

Face milling cutters (43°)

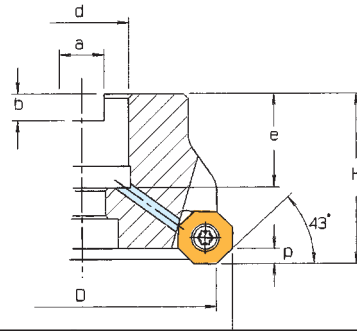
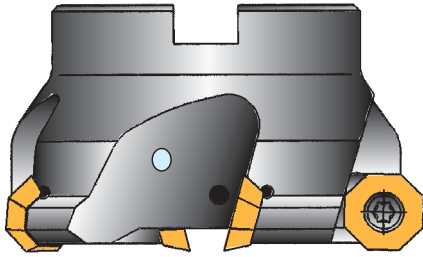
ART. 800 M



Codice d'ordine Bestell-Nr Order No.	(mm) Dimensioni - Abmessungen - Dimensions									Inserto Wendeplatte Insert	Ricambi - Ersatzteile Spare parts	
	D	De	d	e	a	b	H	p	z		Vite - Screw	Chiave - Key
800M-W-D32	32	39	16	19	8,4	5,6	40	3,5	3	OFMT OFEX 05T305	C 06710 	CT 15 
800M-W-D40	40	47	16	19	8,4	5,6	40	3,5	3			
800M-W-D50	50	57	22	22	10,4	6,3	40	3,5	4			
800M-W-D63	63	70	22	22	10,4	6,3	40	3,5	5			
800M-W-D80	80	87	27	28	12,4	7	50	3,5	6			
800M-W-D100	100	107	32	31	12,4	8	50	3,5	7			
800M-W-D125	125	132	40	41	16,4	9	63	3,5	8			

Inserto
Wendeplatte
Insert

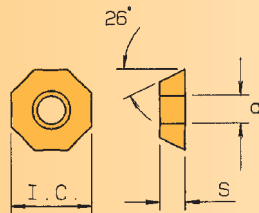



	I.C.	s	d
OFMT 05T305 ... OFEX 05T305 ...	12,7	3,77	4,5

W-W e M-W= Con foro refrigerante - Kuehlmittelbohrung - Coolant bores

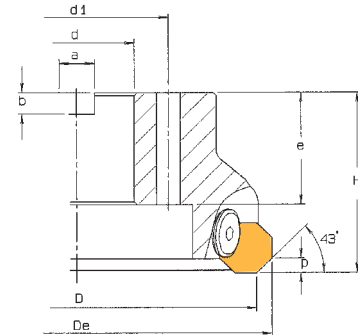
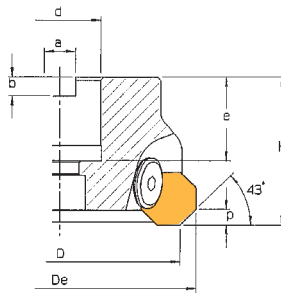
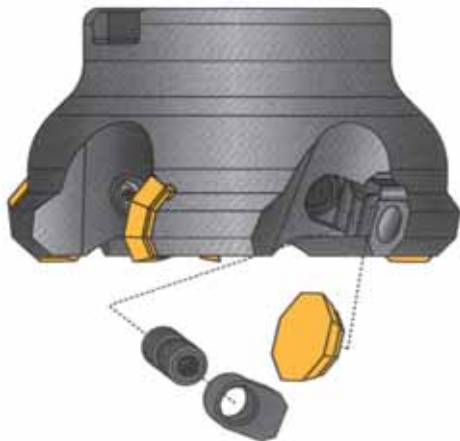
ART. 880 M



Codice d'ordine Bestell-Nr Order No.	(mm) Dimensioni - Abmessungen - Dimensions										Inserto Wendeplatte Insert	Ricambi - Ersatzteile Spare parts	
	D	De	d	d1	e	a	b	H	p	z		Vite di bloccaggio Insert locking screw	Chiave Key
880M-D63	63	73	22	-	22	10,4	6,3	40	5	4	OFER 070405	CVB 88 	ET 4 
880M-D80	80	90	27	-	28	12,4	7	50	5	6			
880M-D100	100	110	32	-	31	14,4	8	50	5	6			
880M-D125	125	135	40	-	41	16,4	9	63	5	8			
880M-D160	160	170	40	66,7	41	16,4	9	63	5	10			

Inserto
Wendeplatte
Insert

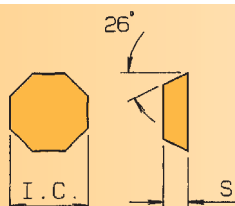

	I.C.	s
OFER 070405	17,94	4,56

W-W e M-W= Con foro refrigerante - Kuehlmittelbohrung - Coolant bores



Frese per spianatura (45°)

Planfraäser (45°)

Face milling cutters (45°)

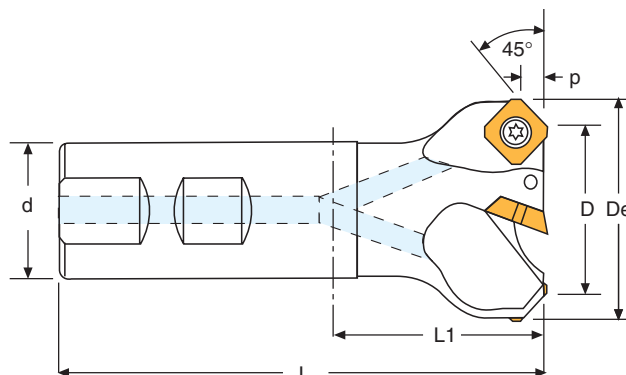
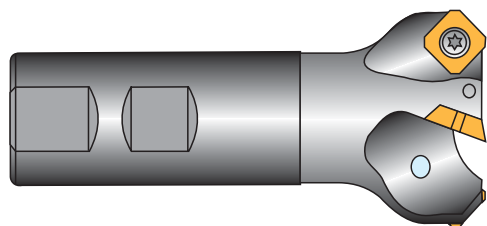

ART. 630 W

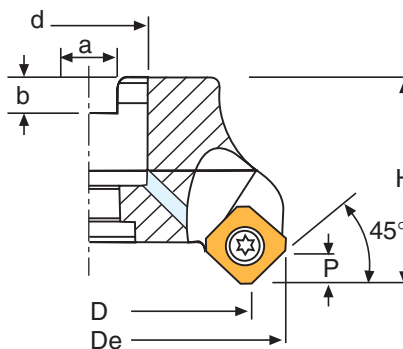
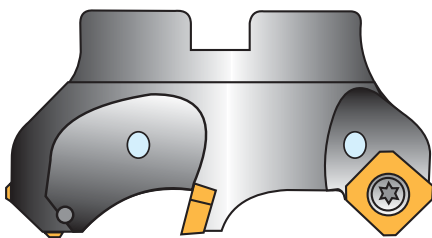

Codice d'ordine Bestell-Nr Order No.	(mm) Dimensioni - Abmessungen - Dimensions							Inserto Wendepatte Insert	Ricambi - Ersatzteile Spare parts	
	D	De	d	L	L1	p	z		Vite - Screw	Chiave - Key
630W-W-D06	6	14,2	16	80	32	4	1	SDHW 09T3... SDHT 09T3...	VT 35 	BT 15 
630W-W-D12	12	20,2	16	80	32	4	1			
630W-W-D16	16	24,2	20	90	40	4	2			
630W-W-D20	20	28,2	20	90	40	4	3			
630W-W-D25	25	33,2	25	100	44	4	4			
630W-W-D32	32	40,2	25	95	39	4	5			

ART. 630 M



Codice d'ordine Bestell-Nr Order No.	(mm) Dimensioni - Abmessungen - Dimensions								Inserto Wendepatte Insert	Ricambi - Ersatzteile Spare parts	
	D	De	d	a	b	H	p	z		Vite - Screw	Chiave - Key
630M-W-D32	32	40,2	16	8,4	5,6	40	4	3	SDHW 09T3... SDHT 09T3...	VT 35 	BT 15 
630M-W-D40	40	48,2	16	8,4	5,6	40	4	4			
630M-W-D50	50	58,2	22	10,4	6,3	40	4	6			
630M-W-D63	63	71,2	22	10,4	6,3	40	4	8			
630M-W-D80	80	88,2	27	12,4	7	50	4	10			

Inserto
Wendepatte
Insert

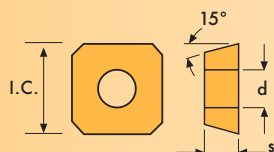



	I.C.	s	d
SDHW SDHT 09T3...	9,5	3,97	4,4

W-W e M-W= Con foro refrigerante - Kuehlmittelbohrung - Coolant bores

Frese a riccio
Schaftschruppfraeser
 Helical end mills

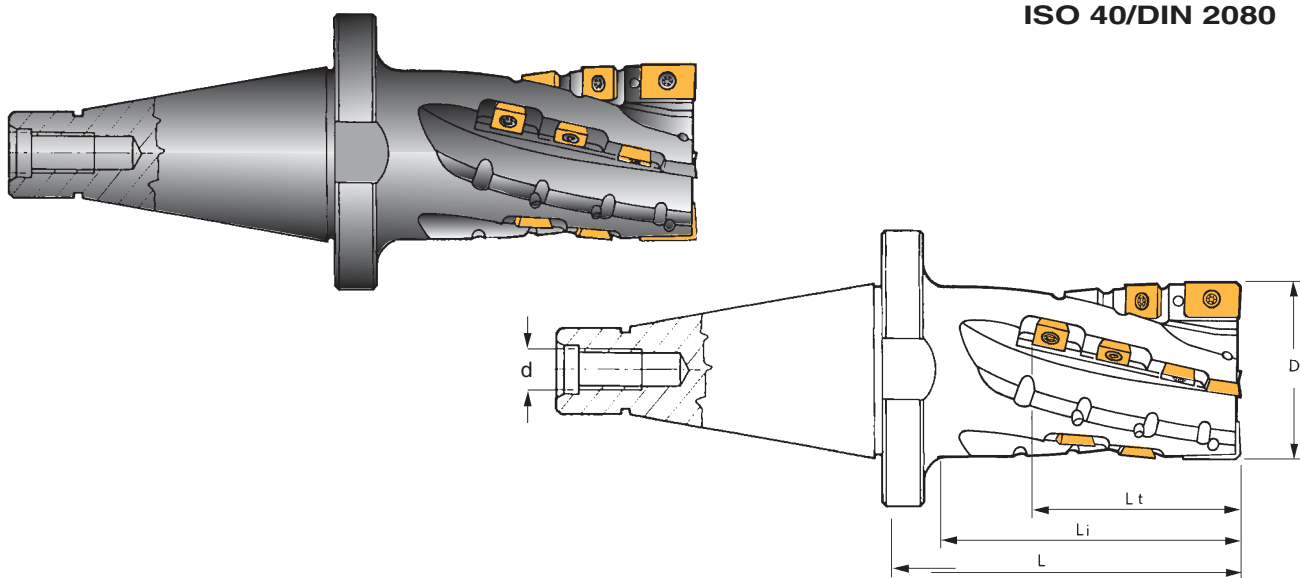

ART. 560 G
 ISO 40/DIN 2080

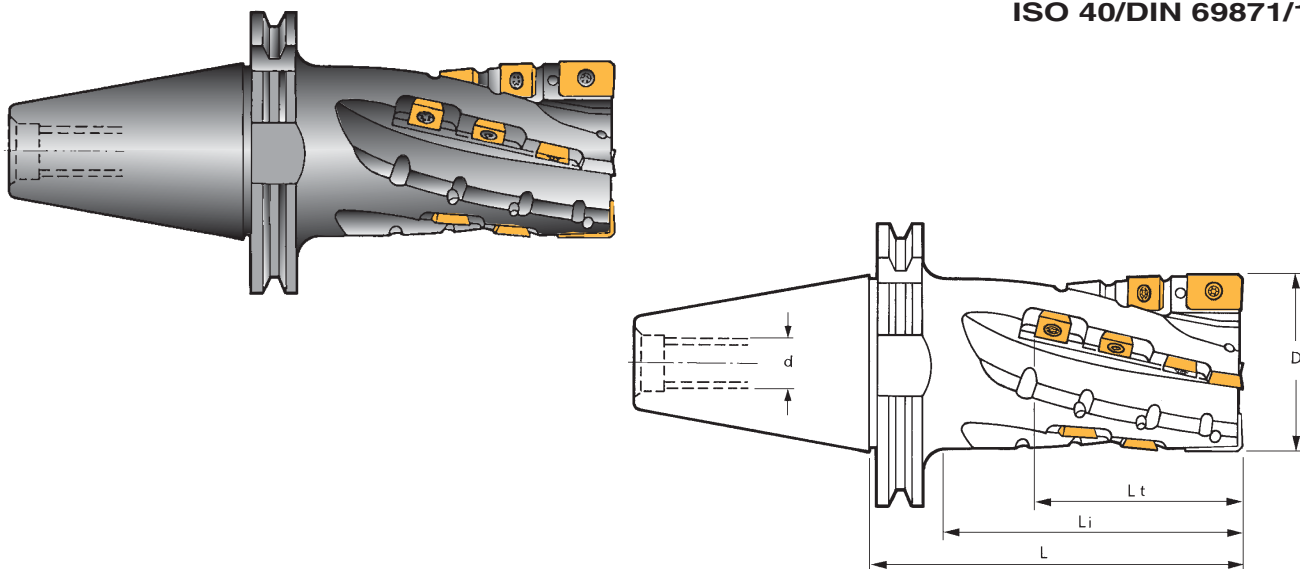

Codice d'ordine Bestell-Nr Order No.	(mm) Dimensioni - Abmessungen - Dimensions							Insero Wendeplatte Insert	Ricambi - Ersatzteile Spare parts	
	D	d	Lt	Li	L	z	ISO		Vite - Screw	Chiave - Key
560G-D40	40	M16	50	70	86	4	40	2-LDMW 150308 12-SDMW 090308	VT 40 	CT 15 

ART. 560 H
 ISO 40/DIN 69871/1





Codice d'ordine Bestell-Nr Order No.	(mm) Dimensioni - Abmessungen - Dimensions							Insero Wendeplatte Insert	Ricambi - Ersatzteile Spare parts	
	D	d	Lt	Li	L	z	ISO		Vite - Screw	Chiave - Key
560H-D40	40	M16	50	70	96	4	40	2-LDMW 150308 12-SDMW 090308	VT 40 	CT 15 

Frese a riccio

Schaftschruppfraeser
Helical end mills

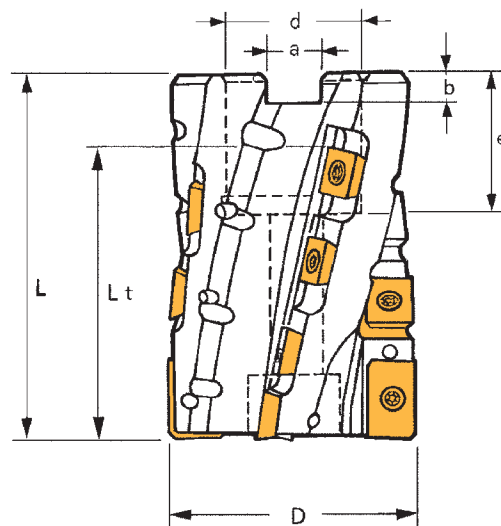
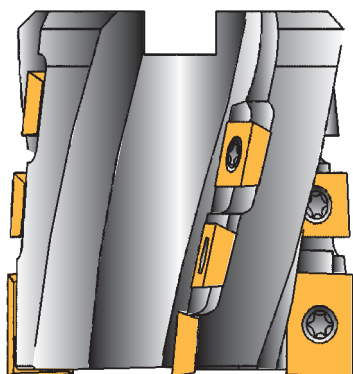
ART. 660 M



Codice d'ordine Bestell-Nr Order No.	(mm) Dimensioni - Abmessungen - Dimensions								Inserto Wendepatte Insert	Ricambi - Ersatzteile Spare parts	
										Vite - Screw	Chiave - Key
	D	d	L	Lt	e	a	b	z			
660M-D50	50	22	53	42	21	10,4	6,3	4	2-LDMW 1503 10-SDMW 0903	VT 40	CT 15
660M-D63	63	27	54	50	28	12,4	7	6	3-LDMW 1503 18-SDMW 0903	VT 40	CT 15
660M-D80	80	32	80	67	28	14,4	8	6	3-LPMW 1504 18-SPMW 1204	VT 50	CT 20

Inserto
Wendepatte
Insert

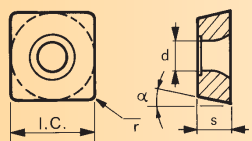
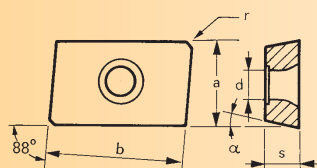

Code	I.C.	s	d	r	α
LDMW 1503...					
ADLX 1503...					
ADLT 1503...	9,52	3,18	4,5	0,8	15°
LPMW 1504...					
APLX 1504...					
APKT 1504...	12,70	4,76	5,5	-	11°
APKA 1504...					

Code	I.C.	s	d	r	α
SDMW 0903...					
SDLT 0903...					
SDKA 0903...	9,52	3,18	4,5	0,8	15°
SPMW 1204...					
SPKA 1204...	12,70	4,76	5,5	0,8	11°

Frese a riccio ISO 50/DIN 2080

Schaftschruppfraeser

Helical end mills

ART. 720 G

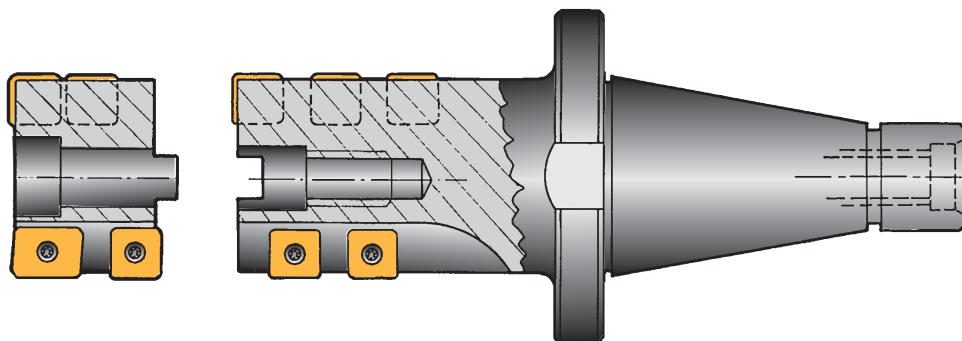

TR-720D

TR = con inserto tondo
MIT RUNDER
WENDEPLATTE
with round insert



TL-720D

TL = lunga
LANG
long

TC-720D

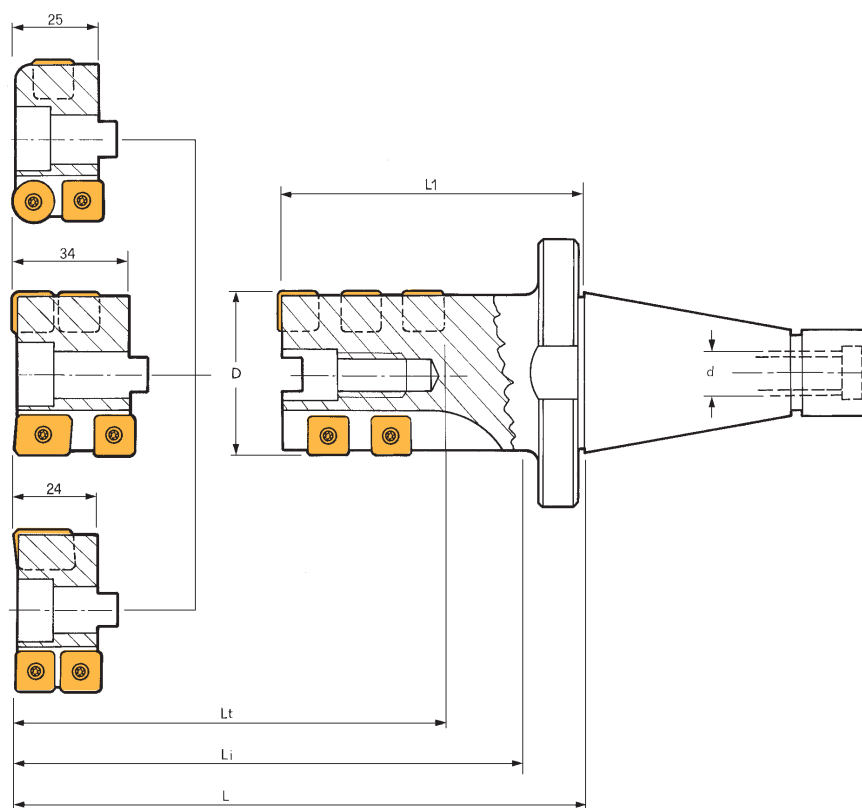
TC = corta
KURZ
short



Codice d'ordine Bestell-Nr Order No.	(mm) Dimensioni - Abmessungen - Dimensions								Inserto Wendeplatte Insert	Ricambi - Ersatzteile Spare parts		
	D	d	Lt	Li	L	L1	z	ISO				
720G-D50C	50	M24	56	80	103	79	4	50	2-LPMW 1504AP 10-SPMW-120408	VT 50	CT 20	VF 50
720G-D50R	50	M24	57	81	104	79	4	50	2-RPCW 1204MO 10-SPMW-120408	VT 40 VT 50	CT 15 CT 20	VF 50
720G-D63C	63	M24	77	100	123	99	4	50	2-LPMW 1504AP 14-SPMW-120408	VT 50	CT 20	VF 63C
720G-D63L	63	M24	87	110	133	99	4	50	2-LPMW 1504AP 16-SPMW-120408	VT 50	CT 20	VF 63L
720G-D63R	63	M24	78	101	124	99	4	50	2-RPCW 1204MO 14-SPMW-120408	VT 40 VT 50	CT 15 CT 20	VF 63C
720G-D80C	80	M24	97	120	143	119	6	50	3-LPMW 1504AP 27-SPMW-120408	VT 50	CT 20	VF 80C
720G-D80L	80	M24	107	130	153	119	6	50	3-LPMW 1504AP 30-SPMW-120408	VT 50	CT 20	VF 80L
720G-D80R	80	M24	98	121	144	119	6	50	3-RPCW 1204MO 27-SPMW-120408	VT 40 VT 50	CT 15 CT 20	VF 80C

Frese a riccio ISO 50/DIN 69871/1

Schaftschruppfraeser

Helical end mills

ART. 720 H

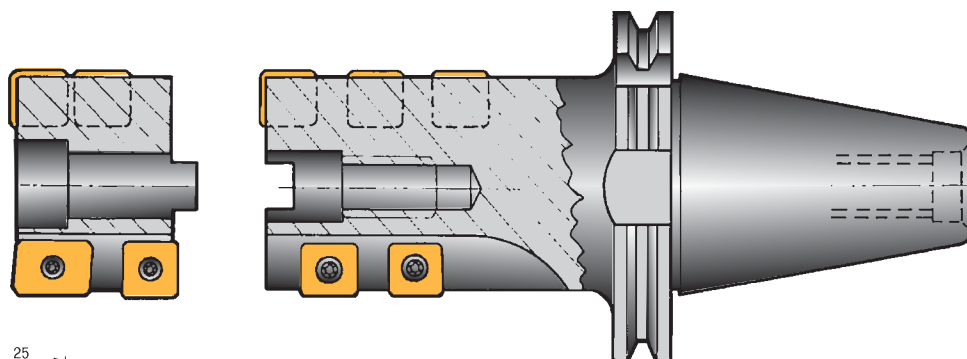

TR-720D
TR = con inserto tondo
MIT RUNDER
WENDEPLATTE
with round insert

TL-720D
TL = lunga
LANG
long

TC-720D
TC = corta
KURZ
short

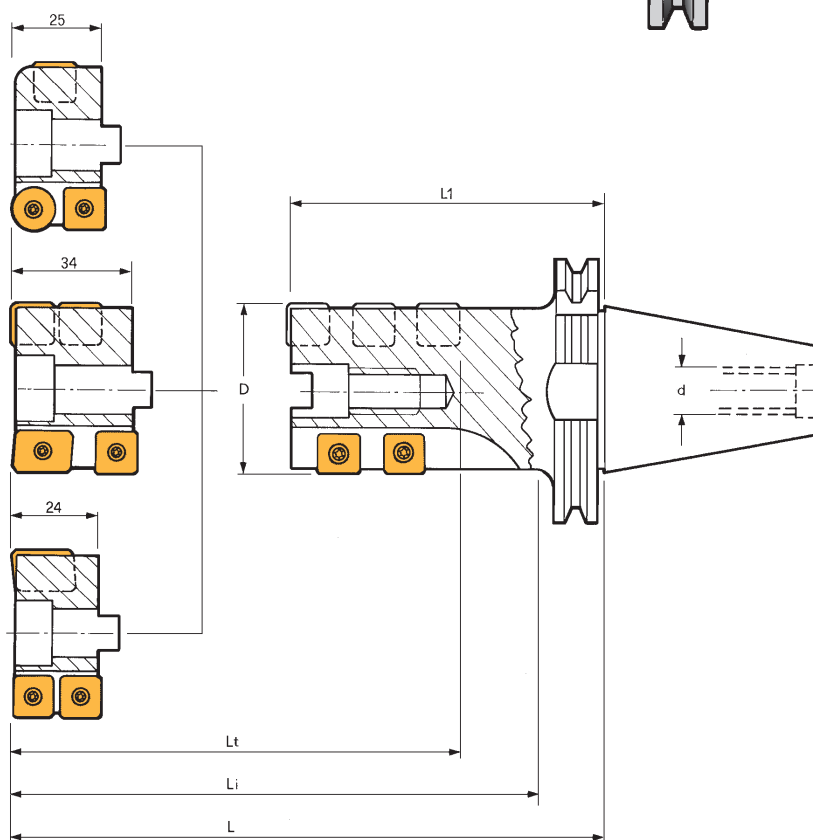

Codice d'ordine Bestell-Nr Order No.	(mm) Dimensioni - Abmessungen - Dimensions								Inserto Wendeplatte Insert	Ricambi - Ersatzteile Spare parts		
	D	d	Lt	Li	L	L1	z	ISO				
720H-D50C	50	M24	56	80	107	83	4	50	2-LPMW 1504AP 10-SPMW-120408	VT 50	CT 20	VF 50
720H-D50R	50	M24	57	81	108	83	4	50	2-RPCW 1204MO 10-SPMW-120408	VT 40 VT 50	CT 15 CT 20	
720H-D63C	63	M24	77	100	127	103	4	50	2-LPMW 1504AP 14-SPMW-120408	VT 50	CT 20	VF 63C
720H-D63L	63	M24	87	110	137	103	4	50	2-LPMW 1504AP 16-SPMW-120408	VT 50	CT 20	VF 63L
720H-D63R	63	M24	78	101	128	103	4	50	2-RPCW 1204MO 14-SPMW-120408	VT 40 VT 50	CT 15 CT 20	VF 63C
720H-D80C	80	M24	97	120	147	123	6	50	3-LPMW 1504AP 27-SPMW-120408	VT 50	CT 20	VF 80C
720H-D80L	80	M24	107	130	157	123	6	50	3-LPMW 1504AP 30-SPMW-120408	VT 50	CT 20	VF 80L
720H-D80R	80	M24	98	121	148	123	6	50	3-RPCW 1204MO 27-SPMW-120408	VT 40 VT 50	CT 15 CT 20	VF 80C

Frese a riccio

Schaftschruppfraeser
Helical end mills

ART. 850 W

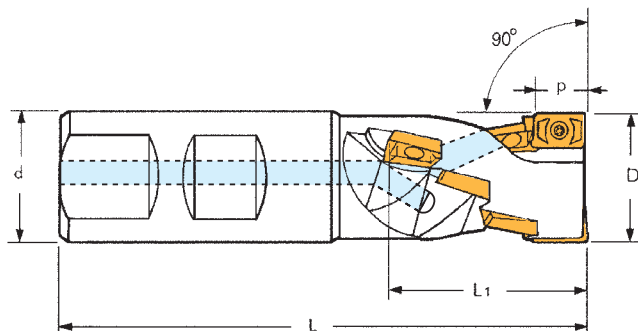
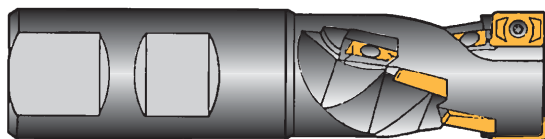

Codice d'ordine Bestell-Nr Order No.	(mm) Dimensioni - Abmessungen - Dimensions						Inserto Wendeplatte Insert n°	Ricambi - Ersatzteile Spare parts		
	D	d	L	L1	p	K		Vite - Screw	Chiave - Key	
850W-W-D25	25	25	105	29	17	1	2	APFT	VT 40	BT 15
850W-W-D32	32	32	115	44	17	2	6	APKT		
850W-W-D40	40	32	130	58	17	2	8	APHT 1604...		

ART. 850 M

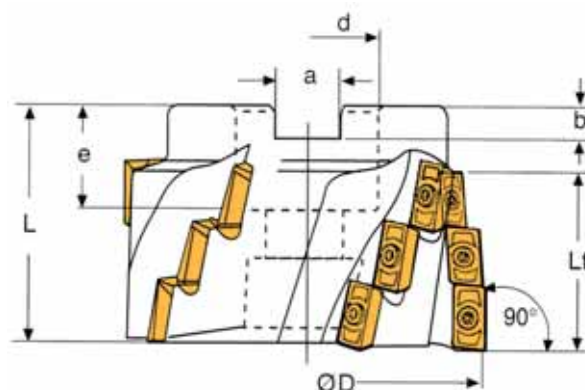
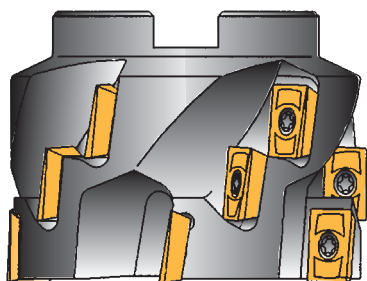

Codice d'ordine Bestell-Nr Order No.	(mm) Dimensioni - Abmessungen - Dimensions								Inserto Wendeplatte Insert n°	Ricambi - Ersatzteile Spare parts		
	D	d	L	Lt	e	a	b	K		Vite - Screw	Chiave - Key	
850M-D50	50	27	50	30	28	12,4	7	3	6	APFT	VT 40	BT 15
850M-D63	63	27	60	44	28	12,4	7	4	12	APKT		
850M-D80	80	32	60	44	28	12,4	8	5	15	APHT		
850M-D100	100	40	60	44	30	16,4	9	6	18	1604...		

Inserto
Wendeplatte
Insert

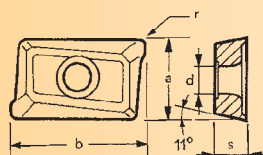

	a	b	s	d	r
APKT 1604...					
APFT 1604...					
APHT 1604...	9,52	17	4,76	4,4	0,8
APHX 1604...					





W-W e M-W= Con foro refrigerante - Kuehlmittelbohrung - Coolant bores

Frese a riccio

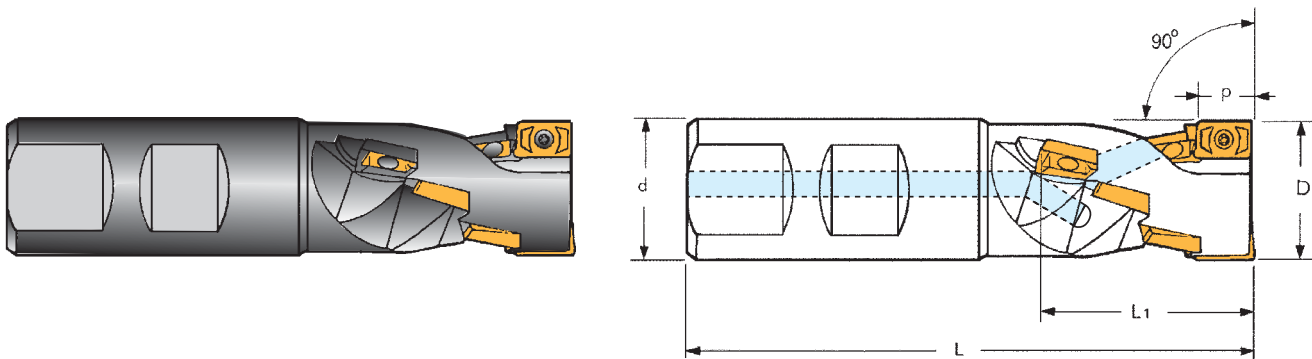
Schaftschruppfraeser
Helical end mills

ART. 900 W





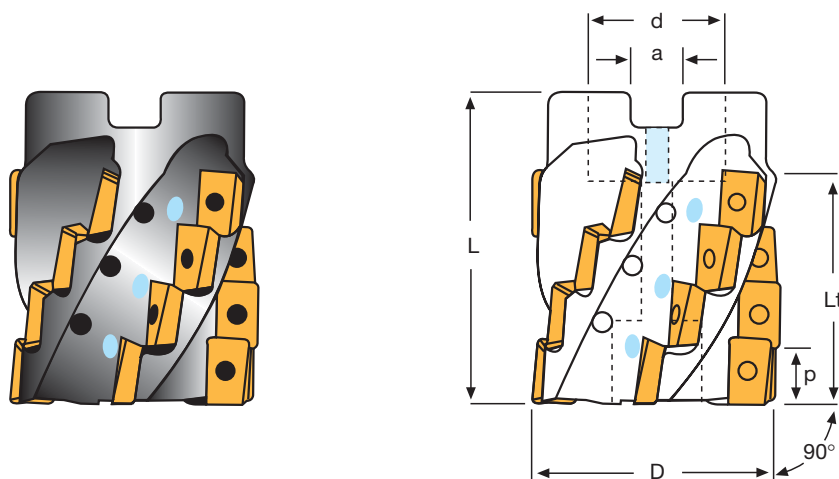

Codice d'ordine Bestell-Nr Order No.	(mm) Dimensioni - Abmessungen - Dimensions						Inserto Wendeplatte Insert n°	Ricambi - Ersatzteile Spare parts	
	D	d	L	L1	p	K		Vite - Screw	Chiave - Key
900W-W-D20	20	20	86	28	10	1	4	VT 25	BT 08
900W-W-D25	25	25	100	36	10	2	8	 	 
900W-W-D32/2	32	32	120	45	10	2			
900W-W-D32/3	32	32	120	45	10	3			
900W-W-D40	40	32	130	54	10	2			

ART. 900 MW



NOVITÀ
NEU
NEW

Codice d'ordine Bestell-Nr Order No.	(mm) Dimensioni - Abmessungen - Dimensions						Inserto Wendeplatte Insert n°	Ricambi - Ersatzteile Spare parts	
	D	d	L	Lt	p	K		Vite - Screw	Chiave - Key
900M-W-D40	40	16	50	37	10	3	12	 	 
900M-W-D50	50	22	60	46	10	3			
900M-W-D63	63	27	60	46	10	4			

Inserto
Wendeplatte
Insert

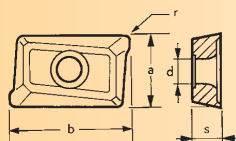

	a	b	s	d	r
APKT 1003...					
APHT 1003...	6,7	10,8	3,55	2,8	0,5
APHX 1003...					

W-W e M-W= Con foro refrigerante - Kuehlmittelbohrung - Coolant bores

Frese per scanalature e taglio

Scheibenfräser

Grooving and cut-off mills

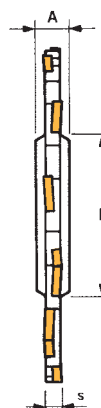
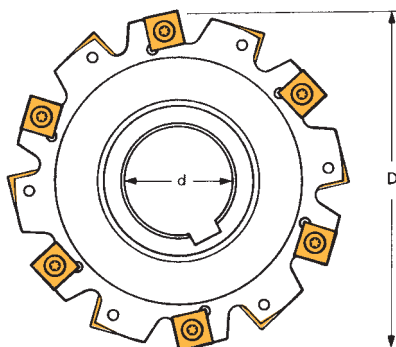
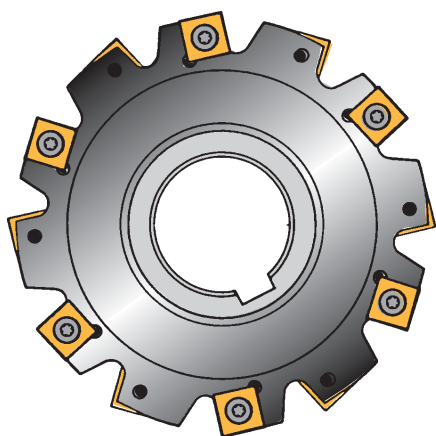

ART. 610

Angolo assiale - 3°
 Angolo radiale - 12°
 Axial winkel - 3°
 Radial winkel - 12°
 Axial rake - 3°
 Radial rake - 12°

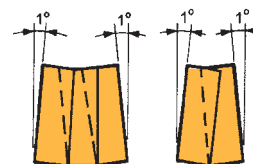

Codice d'ordine Bestell-Nr Order No.	(mm) Dimensioni - Abmessungen - Dimensions									Inserto Wendeplatte Insert	Ricambi - Ersatzteile Spare parts	
	D	d	s	A	B	Z	Fattore K	Max Prof. di taglio	Vite - Screw		Chiave - Key	
610-63-04	63	22	4	8	34	8	4	14	SNHX 1102T	VTX 3503	CT 09	
-05	63	22	5	8	34	8	4	14	SNHX 1103T	VTX 3504	CT 09	
-06	63	22	6	8	34	6	3	14	SNHX 1203T	VTX 405	CT 15	
610-80-04	80	22	4	8	34	10	5	22	SNHX 1102T	VTX 3503	CT 09	
-05	80	22	5	8	34	10	5	22	SNHX 1103T	VTX 3504	CT 09	
-06	80	22	6	8	34	8	4	22	SNHX 1203T	VTX 405	CT 15	
610-100-04	100	27	4	12	45	12	6	27	SNHX 1102T	VTX 3503	CT 09	
-05	100	27	5	12	45	12	6	27	SNHX 1103T	VTX 3504	CT 09	
-06	100	27	6	12	45	10	5	27	SNHX 1203T	VTX 405	CT 15	
-07	100	27	7	12	45	9	3	27	SNHX 1203T	VTX 405	CT 15	
-08	100	27	8	12	45	9	3	27	SNHX 1203T	VTX 405	CT 15	
-09	100	27	9	12	45	10	5	27	SNHX 1205T	VTX 408	CT 15	
-10	100	27	10	12	45	10	5	27	SNHX 1205T	VTX 408	CT 15	
610-125-04	125	32	4	12	58	14	7	33	SNHX 1102T	VTX 3503	CT 09	
-05	125	32	5	12	58	14	7	33	SNHX 1103T	VTX 3504	CT 09	
-06	125	32	6	12	58	12	6	33	SNHX 1203T	VTX 405	CT 15	
-07	125	32	7	12	58	12	4	33	SNHX 1203T	VTX 405	CT 15	
-08	125	32	8	12	58	12	4	33	SNHX 1203T	VTX 405	CT 15	
-09	125	32	9	12	58	12	6	33	SNHX 1205T	VTX 408	CT 15	
-10	125	32	10	12	58	12	6	33	SNHX 1205T	VTX 408	CT 15	
-12	125	32	12	12	58	12	4	33	SNHX 1205T	VTX 408	CT 15	
610-160-04	160	40	4	12	68	18	9	45	SNHX 1102T	VTX 3503	CT 09	
-05	160	40	5	12	68	18	9	45	SNHX 1103T	VTX 3504	CT 09	
-06	160	40	6	12	68	16	8	45	SNHX 1203T	VTX 405	CT 15	
-07	160	40	7	12	68	15	5	45	SNHX 1203T	VTX 405	CT 15	
-08	160	40	8	12	68	15	5	45	SNHX 1203T	VTX 405	CT 15	
-09	160	40	9	12	68	16	8	45	SNHX 1205T	VTX 408	CT 15	
-10	160	40	10	12	68	16	8	45	SNHX 1205T	VTX 408	CT 15	
-12	160	40	12	12	68	15	5	45	SNHX 1205T	VTX 408	CT 15	
-14	160	40	14	14	68	15	5	45	SNHX 1205T	VTX 408	CT 15	
610-200-04	200	50	4	12	72	18	9	63	SNHX 1102T	VTX 3503	CT 09	
-05	200	50	5	12	72	18	9	63	SNHX 1103T	VTX 3504	CT 09	
-06	200	50	6	12	72	18	9	63	SNHX 1203T	VTX 405	CT 15	
-08	200	50	8	12	72	18	6	63	SNHX 1203T	VTX 405	CT 15	
-10	200	50	10	12	72	18	9	63	SNHX 1205T	VTX 408	CT 15	
-12	200	50	12	12	72	18	6	63	SNHX 1205T	VTX 408	CT 15	
-14	200	50	14	14	72	18	6	63	SNHX 1205T	VTX 408	CT 15	
610-250-08	250	50	8	12	72	24	8	88	SNHX 1203T	VTX 405	CT 15	
-10	250	50	10	12	72	24	12	88	SNHX 1205T	VTX 408	CT 15	
-12	250	50	12	12	72	24	8	88	SNHX 1205T	VTX 408	CT 15	
-14	250	50	14	14	72	24	8	88	SNHX 1205T	VTX 408	CT 15	

Inserto
Wendeplatte
Insert

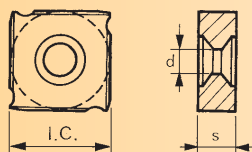

	a	s	d
SNHX 1102T	11,0	2,3	4,4
SNHX 1103T	11,0	2,7	4,4
SNHX 1203T	12,7	3,2	5,0
SNHX 1205T	12,7	5,4	5,0

Frese per scanalature e taglio

Scheibenfräser

Grooving and cut-off mills

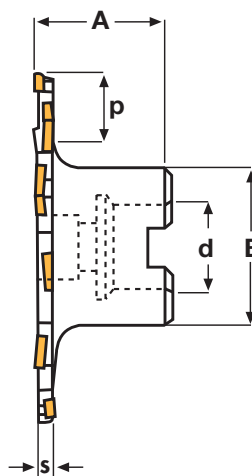
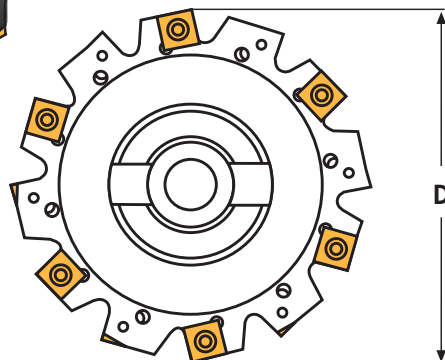
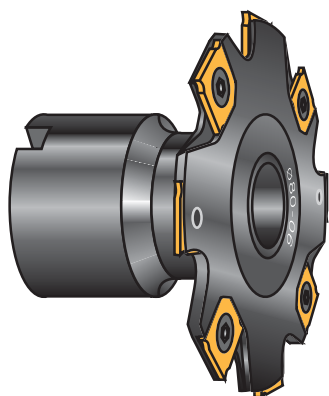

ART. 610 M

Angolo assiale - 3°

Angolo radiale - 12°



Axial winkel 3°

Radial winkel - 12°

Axial rake 3°

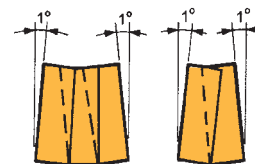
Radial rake - 12°



Codice d'ordine Bestell-Nr Order No.	(mm) Dimensioni - Abmessungen - Dimensions								Inserto Wendeplatte Insert	Ricambi - Ersatzteile Spare parts	
	D	d	s	A	B	Z	Fattore K	Max Prof. di taglio		Vite - Screw	Chiave - Key
											
610M-63-04	63	22	4	50	40	6	3	10,5	SNHX 1102T	VTX 3503	CT 09
-05	63	22	5	50	40	6	3	10,5	SNHX 1103T	VTX 3504	CT 09
-06	63	22	6	50	40	6	3	10,5	SNHX 1203T	VTX 405	CT 15
610M-80-04	80	22	4	50	40	8	4	20,2	SNHX 1102T	VTX 3503	CT 09
-05	80	22	5	50	40	8	4	20,2	SNHX 1103T	VTX 3504	CT 09
-06	80	22	6	50	40	8	4	20,2	SNHX 1203T	VTX 405	CT 15
610M-100-04	100	27	4	50	48	12	6	24,2	SNHX 1102T	VTX 3503	CT 09
-05	100	27	5	50	48	12	6	24,2	SNHX 1103T	VTX 3504	CT 09
-06	100	27	6	50	48	10	5	24,2	SNHX 1203T	VTX 405	CT 15
-10	100	27	10	50	48	10	5	24,2	SNHX 1205T	VTX 408	CT 15
610M-125-06	125	40	6	50	70	12	6	23,7	SNHX 1203T	VTX 405	CT 15
-10	125	40	10	50	70	12	6	23,7	SNHX 1205T	VTX 408	CT 15
610M-160-06	160	40	6	50	70	16	8	41,2	SNHX 1203T	VTX 405	CT 15
-10	160	40	10	50	70	16	8	41,2	SNHX 1205T	VTX 408	CT 15

Fresa
Fraeser
Milling

Inserto
Wendeplatte
Insert

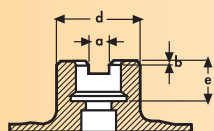

FRESA - FRAESER MILLING	d	a	b	e
610M-63	22	10,4	6,3	21
610M-80	22	10,4	6,3	21
610M-100	27	12,4	7	23
610M-125	40	16,4	9	30
610M-160	40	16,4	9	30

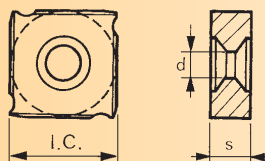

	I.C.	s	d
SNHX 1102T	11,0	2,3	4,4
SNHX 1103T	11,0	2,7	4,4
SNHX 1203T	12,7	3,2	5,0
SNHX 1205T	12,7	5,4	5,0