



**MANUAL / AUTOMATIC INDEX ARM**

▲ All types of indexations  
*Tous les types d'indexation*  
Alle Type von Indexierungen  
*Todo tipo de indexaciones*

**STANDARD STOP BLOCK**

▲ Stop-block suitable for all machines types, available on request  
*Stop-block, livrable sur demande, suivant les caractéristiques de la machine*  
Anschlagblock lieferbar auf Anfrage, Abmessungen je nach Maschinentyp  
*Stop-block disponible bajo demanda, para todo tipo de máquina*

▲ Standard equipment  
*Équipement standard*  
Standardlieferung  
*Equipo estandar*



▲ Collets  
*Pinces*  
Spannzangen  
*Pinzas*

| TYPE  | Capacity | STEP mm |
|-------|----------|---------|
| ER 16 | 0,5-10   | 1       |
| ER 20 | 1-13     | 1       |
| ER25  | 1-16     | 1       |
| ER 32 | 2-20     | 1       |
| ER 40 | 3-26     | 1       |
| ER 50 | 10-34    | 2       |

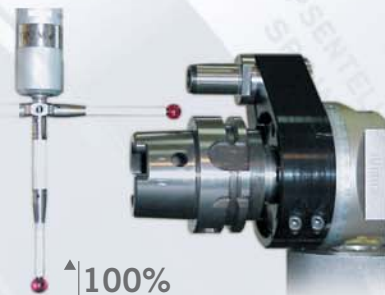

▲ 100%  
Tested / *Testés* / Überprüft / *Probados*

**OTHER PRODUCTS**

Live tooling for all types of machines. More than 100 standard models  
*Porte-outils entraînés pour tous types de machines. Plus de 100 modèles standard*  
Angetriebene Werkzeughalter für alle Type von Maschinen. Mehr als 100 Standardtype  
*Portaherramientas motorizadas para todo tipo de máquina.*  
*Más de 100 modelos standard*

Multispindle heads. 16 standard models  
*Têtes multibroches. 16 modèles standard*  
Mehrspindelköpfe. 16 Standardtype  
*Cabezales múltiples. 16 modelos standard*

Angle heads. 28 standard models  
*Têtes à renvoi. 28 modèles standard*  
Winkelköpfe. 28 Standardtype  
*Cabezales angulares. 28 modelos standard*



More than 6000 special manufactured types  
*Plus de 6000 modèles spéciaux déjà fabriqués*  
Über 6000 Varianten zusätzlich zum Standard  
*Más de 6000 variantes realizadas sobre nuestro estándar*



Rec del Molí, 11-17  
08105 - Sant Fost de Campsentelles  
BARCELONA - SPAIN  
Tel. 34 93 593 36 00  
Fax. 34 93 570 07 99  
www.madaula.com  
e-mail: comercial@madaula.com



JCS DESIGN & PUBLISHTV, 93 786 12 64

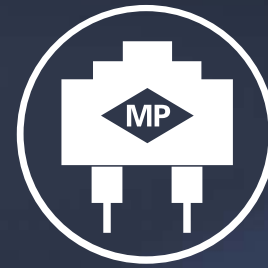

**MADAULA S.A.**  
www.madaula.com®

Spindle Speeders / *Multiplicateurs de Vitesse*  
Schnellaufspindeln / *Multiplificadores de velocidad*





► Spindle speeders

- Smooth and quiet running
- Precise and rigid compact manufacture
- Very high output per tool
- No maintenance, greased for life
- Great rigidity and high precision
- Maximum concentricity
- Other clamping systems, on request, (ABS, EPB, WELDON...)
- Adaptable to any model of machine
- Available with any type of taper
- Increases tool and machine life
- Tailor made to meet customer specifications upon request

► Multiplicateurs de vitesse

- *Fonctionnement souple et silencieux*
- *Fabrication de précision, solide et très rigide*
- *Grande capacité d'enlèvement des copeaux*
- *Entretien minimum, graissage à vie*
- *Grande rigidité et haute précision*
- *Concentricité maximale*
- *Autres sorties de broche sur demande, (ABS, EPB, WELDON...)*
- *Adaptable sur toutes les machines*
- *Livrable avec tout type de cône*
- *Augmente et améliore la durée de vie des outils et de la machine*
- *Exécution de multiplicateurs spéciaux sur demande*

► Schnellaufspindeln

- Ruhiger und geräuscharmer Lauf
- Präzise und solide, starre Bauart
- Grosse spanabhebende Leistung
- Wartungsfrei, Dauerschmierung
- Grosse Starrheit und höchste Präzision
- Max Konzentrität
- Andere Werkzeughaltersysteme auf Anfrage (ABS, EPB, WELDON...)
- Anpassbar an jede Art von Maschine oder Bearbeitungszentren
- Verfügbar mit jeder Kegeltyp
- Verlängert die Standzeit des Werkzeuges und die Lebensdauer der Maschine
- Sonderausführungen auf Anfrage

► Multiplicadores de velocidad

- *Funcionamiento suave y silencioso*
- *Construcción rígida y precisa*
- *Gran capacidad de arranque de viruta*
- *Engrase a vida, sin mantenimiento*
- *Gran rigidez, alta precisión*
- *Concentricidad máxima*
- *Otros sistemas de fijación, (ABS, EPB, WELDON... bajo demanda)*
- *Adaptable a cualquier tipo de máquina*
- *Disponibile en cualquier tipo de cono*
- *Prolonga la vida de las herramientas y de las máquinas*
- *Ejecución de multiplicadores especiales bajo demanda*

MV-5



RPM:8000  
Ø Max.20

MV-6



RPM:10.000  
Ø Max.16

MV-7



RPM:15.000  
Ø Max.13

MV-8



RPM:20.000  
Ø Max.10

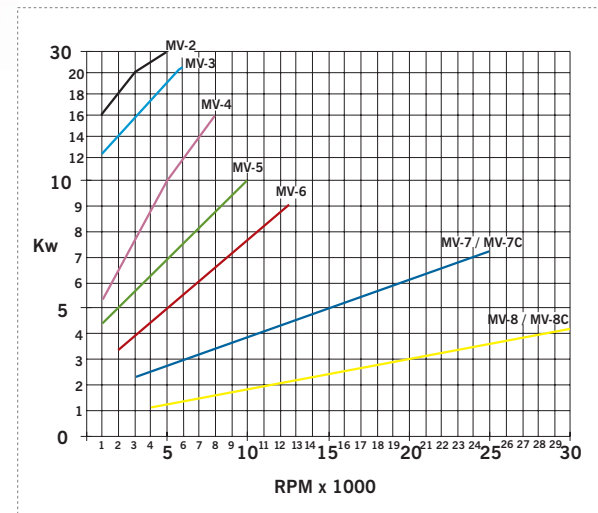

CERAMIC

Precision bearings with ceramic balls  
Roulements de précision à billes céramiques  
Hochpräzisionskeramische Lager  
Rodamientos cerámicos de precisión

MV-7C



RPM:25.000  
Ø Max.13

MV-8C



RPM:30.000  
Ø Max.10

FEATURES / CARACTÉRISTIQUES / MERKMALE / CARACTERÍSTICAS

|       | R.P.M. | ←   | L   | Ø D | Ø d    | ⊠     | kg  | ← SIZE   | HSK SIZE |
|-------|--------|-----|-----|-----|--------|-------|-----|----------|----------|
| MV-7C | 25.000 | 1:7 | 126 | 105 | 1-13   | ER-20 | 5   | 40/50    | 63/80    |
| MV-8C | 30.000 | 1:5 | 115 | 76  | 0.5-10 | ER-16 | 2,5 | 30/40 R8 | 63       |

HIGHER ROTATIONAL SPEED / VITESSE DE ROTATION AUGMENTÉE  
HÖCHSTE SPINDELDREHZAHN / ALTA VELOCIDAD DE ROTACIÓN

MV-4N



RPM:8.000  
Ø Max.26 OR  
ISO 40

MV-3N



RPM:5.000  
Ø Max.34 OR  
ISO 40/50

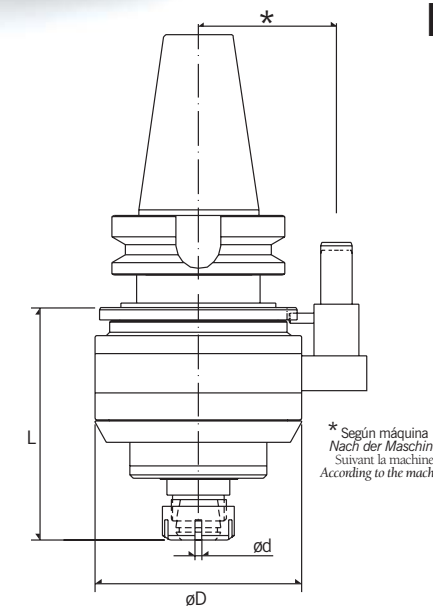
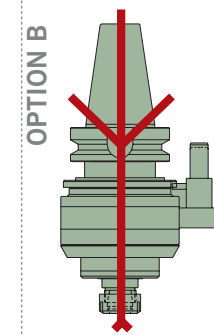
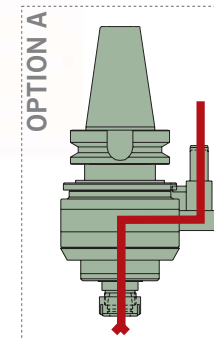
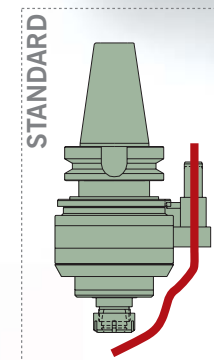

MV-2

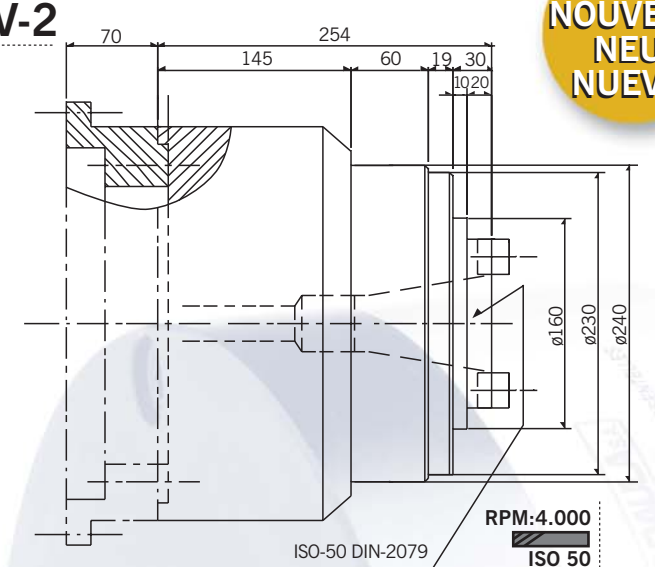

NEW  
NOUVEAU  
NEU  
NUEVO

FEATURES / CARACTÉRISTIQUES / MERKMALE / CARACTERÍSTICAS

|       | R.P.M. | R.P.M. max | ←     | L   | Ø D | Ø d    | ⊠            | kg  | ← SIZE       | HSK SIZE        |
|-------|--------|------------|-------|-----|-----|--------|--------------|-----|--------------|-----------------|
| MV-2  | 4.000  | 5.000      | 1:4   | 300 | -   | -      | ISO-50       | 160 | UNION FLANGE | FLASQUE FLANSCH |
| MV-3N | 5.000  | 6.000      | 1:4   | 227 | 300 | -      | ISO-50       | 65  | 50/60        | -               |
| MV-4N | 8.000  | 10.000     | 1:3,5 | 184 | 236 | 34     | ER-50/ISO-40 | 25  | 50/60        | -               |
| MV-5  | 8.000  | 10.000     | 1:6   | 164 | 150 | 2-20   | ER-32        | 15  | 50           | 100             |
| MV-6  | 10.000 | 12.000     | 1:6   | 134 | 120 | 1-16   | ER-25        | 7   | 50           | 80/100          |
| MV-7  | 15.000 | 18.000     | 1:7   | 126 | 105 | 1-13   | ER-20        | 5   | 40/50        | 63/80           |
| MV-8  | 20.000 | 25.000     | 1:5   | 115 | 76  | 0.5-10 | ER-16        | 2,5 | 30/40 R8     | 63              |

AVAILABLE WITH ANY TYPE OF TAPER / LIVRABLE AVEC TOUT  
TYPE DE CÔNE / VERFÜGBAR MIT JEDER KEGELTYPE /  
SUMINISTRABLE EN CUALQUIER TIPO DE CONO