



T O O L I N G

MINITOLS



Utensili per tornitura interna

Werkzeuge fuer innenbearbeitung

Internal turning tools

SET K-SCLCR/L 06/4

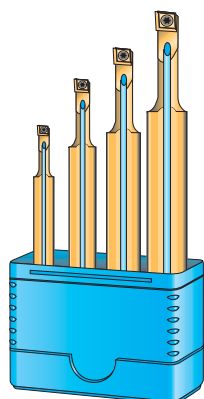

N° 1 K 0608H SCLCR/L 06
 N° 1 K 0810J SCLCR/L 06
 N° 1 K 1012K SCLCR/L 06
 N° 1 K 1216M SCLCR/L 06

SET E SCLCR/L 06

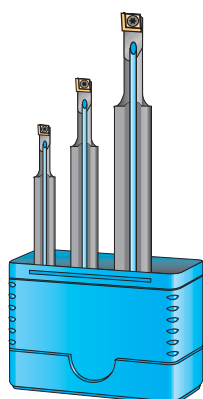

N° 1 E 08K SCLCR/L 06
 N° 1 E 10K SCLCR/L 06
 N° 1 E 12K SCLCR/L 06

SET A-SCLCR/L 06

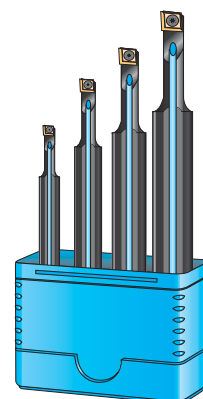

N° 1 A 0608H SCLCR/L 06
 N° 1 A 0810J SCLCR/L 06
 N° 1 A 1012K SCLCR/L 06
 N° 1 A 1216M SCLCR/L 06

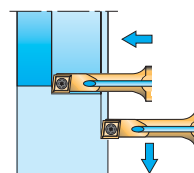
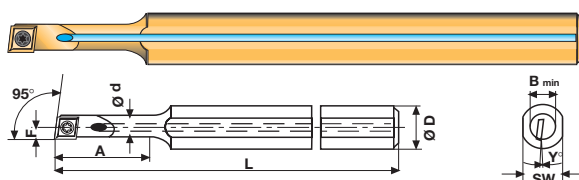

Codice d'ordine Bestell-Nr. Order No.	(mm) Dimensioni - Abmessungen - Dimensions										
	D	d	L	F	B	A	Y°	SW			
K 0608H SCLCR/L 06	8	6	100	4	8	25	18°	7	CCMT - CCGT 0602...	BT08	VT 25
K 0810J SCLCR/L 06	10	8	110	6	12	32	15°	9	CCMT - CCGT 0602...	BT08	VT 25
K 1012K SCLCR/L 06	12	10	125	7	14	38	13°	11	CCMT - CCGT 0602...	BT08	VT 25
K 1216M SCLCR/L 06	16	12	150	9	18	50	10°	15	CCMT - CCGT 0602...	BT08	VT 25

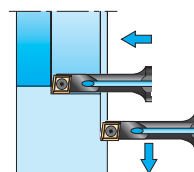
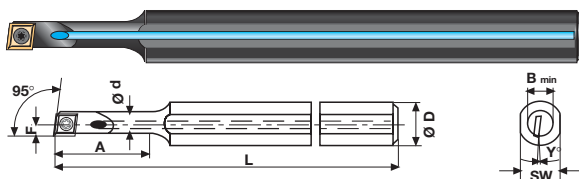

Codice d'ordine Bestell-Nr. Order No.	(mm) Dimensioni - Abmessungen - Dimensions										
	D	d	L	F	B	A	Y°	SW			
A 0608H SCLCR/L 06	8	6	100	4	8	25	18°	7	CCMT - CCGT 0602...	BT08	VT 25
A 0810J SCLCR/L 06	10	8	110	6	12	32	15°	9	CCMT - CCGT 0602...	BT08	VT 25
A 1012K SCLCR/L 06	12	10	125	7	14	38	13°	11	CCMT - CCGT 0602...	BT08	VT 25
A 1216M SCLCR/L 06	16	12	150	9	18	50	10°	15	CCMT - CCGT 0602...	BT08	VT 25

Codice d'ordine Bestell-Nr. Order No.	(mm) Dimensioni - Abmessungen - Dimensions										
	D	d	L	F	B	A	Y°	SW			
E 0608H SCLCR/L 06	8	6	100	4	8	25	18°	7	CCMT - CCGT 0602...	BT08	VT 25
E 0810J SCLCR/L 06	10	8	110	6	12	32	15°	9	CCMT - CCGT 0602...	BT08	VT 25
E 1012K SCLCR/L 06	12	10	125	7	14	38	13°	11	CCMT - CCGT 0602...	BT08	VT 25
E 1216M SCLCR/L 06	16	12	150	9	18	50	10°	15	CCMT - CCGT 0602...	BT08	VT 25

E... SCLC - Codolo in metallo duro con foro refrigerante - Hartmetallschaft mit Kühlmittelbohrung - Carbide shank with coolant bares.

K... SCLC - Codolo in metallo pesante con foro refrigerante - Densimetschaft mit Kühlmittelbohrung - Densimet shank with coolant bares.

Utensili per tornitura interna

Werkzeuge fuer innenbearbeitung

Internal turning tools

SET K-SWUCR/L 02/2

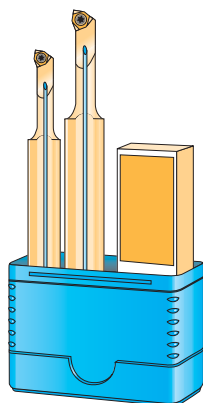

N° 1 K 0508H SWUCR/L 02
N° 1 K 0608H SWUCR/L 02
N° 10 WCMT 020104 X 55

SET A-SWUCR/L 02

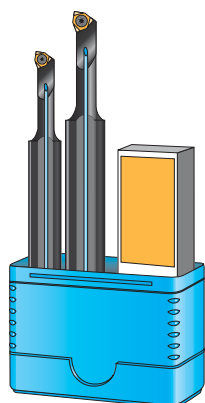

N° 1 A 0508H SWUCR/L 02
N° 1 A 0608H SWUCR/L 02
N° 10 WCMT 020104 X 55

SET E-SWUCR/L 02

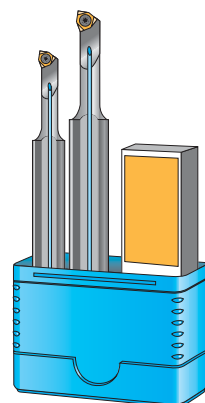

N° 1 E 0508H SWUCR/L 02
N° 1 E 0608H SWUCR/L 02
N° 10 WCMT 020104 X 55

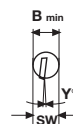

Codice d'ordine Bestell-Nr. Order No.	(mm) Dimensioni - Abmessungen - Dimensions										
	D	d	L	F	B	A	Y°	SW			
K 06H SWUCR/L 02	6	6	100	3,1	6,2	6xD	17°	5	WCMT-WCGT 0201...	BT06	VT22

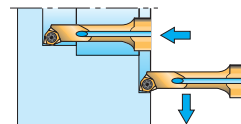
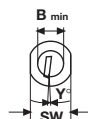
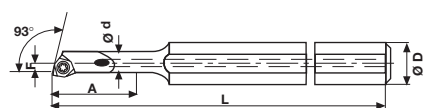

Codice d'ordine Bestell-Nr. Order No.	(mm) Dimensioni - Abmessungen - Dimensions										
	D	d	L	F	B	A	Y°	SW			
K 0508H SWUCR/L 02	8	5	100	2,9	5,8	18	17°	7	WCMT-WCGT 0201...	BT06	VT22
K 0608H SWUCR/L 02	8	6	100	3,9	7,8	24	12°	7	WCMT-WCGT 0201...	BT06	VT22

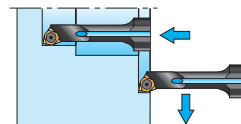
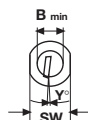
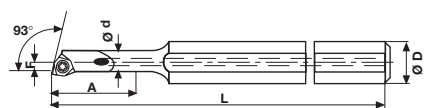

Codice d'ordine Bestell-Nr. Order No.	(mm) Dimensioni - Abmessungen - Dimensions										
	D	d	L	F	B	A	Y°	SW			
A 0508H SWUCR/L 02	8	5	100	2,9	5,8	18	17°	7	WCMT-WCGT 0201...	BT06	VT22
A 0608H SWUCR/L 02	8	6	100	3,9	7,8	24	12°	7	WCMT-WCGT 0201...	BT06	VT22
E 0508H SWUCR/L 02	8	5	100	2,9	5,8	18	17°	7	WCMT-WCGT 0201...	BT06	VT22
E 0608H SWUCR/L 02	8	6	100	3,9	7,8	24	12°	7	WCMT-WCGT 0201...	BT06	VT22

E... SCLC - Codolo in metallo con foro refrigerante - Hartmetallschaft mit Kühlmittelbohrung - Carbide shank with coolant bore.

K... SCLC - Codolo in metallo pesante con foro refrigerante - Densimetschaft mit Kühlmittelbohrung - Densimet shank with coolant bore.

Utensili per tornitura interna

Werkzeuge fuer innenbearbeitung
Internal turning tools

SET A-SDUCR/L 07

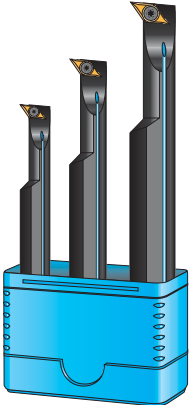

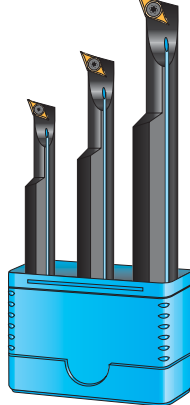

N° 1 A 0810H SDUCR/L 07
N° 1 A 1012K SDUCR/L 07
N° 1 A 1216M SDUCR/L 07

SET A-SDQCR/L 07



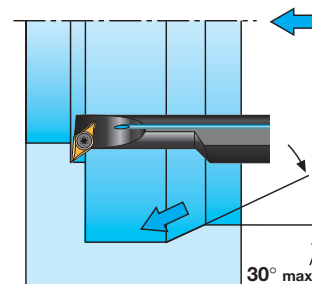
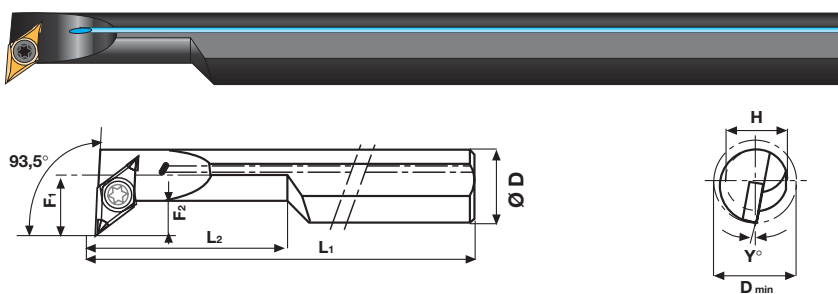

N° 1 A 0810H SDQCR/L 07
N° 1 A 1012K SDQCR/L 07
N° 1 A 1216M SDQCR/L 07

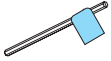

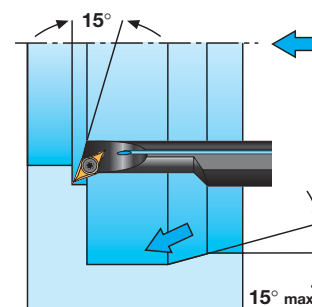
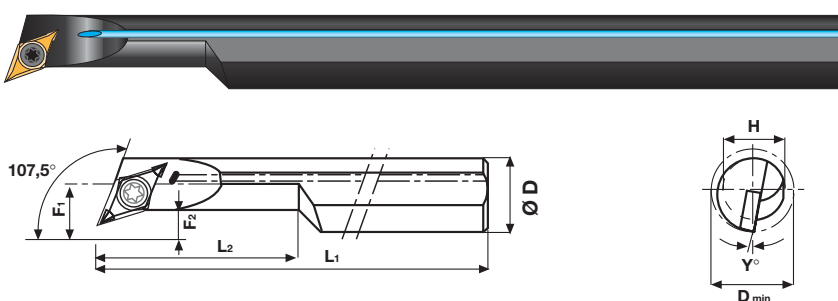
Codice d'ordine Bestell-Nr. Order No.	(mm) Dimensioni - Abmessungen - Dimensions										
	D	L ₁	L ₂	F ₁	F ₂	D _{min}	Y°	H			
A 0810H SDUCR/L 07	10	100	22	7	5	12,5	15°	9	DCMT - DCGT 0702 ...	VT25	BT08
A 1012K SDUCR/L 07	12	125	28	9	5	15,5	13°	11	DCMT - DCGT 0702 ...	VT25	BT08
A 1216M SDUCR/L 07	16	150	36	11	5	19,5	10°	15	DCMT - DCGT 0702 ...	VT25	BT08

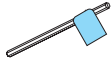

Codice d'ordine Bestell-Nr. Order No.	(mm) Dimensioni - Abmessungen - Dimensions										
	D	L ₁	L ₂	F ₁	F ₂	D _{min}	Y°	H			
A 0810H SDQCR/L 07	10	100	22	7	3	12,5	15°	9	DCMT - DCGT 0702 ...	VT25	BT08
A 1012K SDQCR/L 07	12	125	28	9	3	15,5	13°	11	DCMT - DCGT 0702 ...	VT25	BT08
A 1216M SDQCR/L 07	16	150	36	11	3	19,5	10°	15	DCMT - DCGT 0702 ...	VT25	BT08

Utensili per tornitura interna

Werkzeuge fuer innenbearbeitung
Internal turning tools

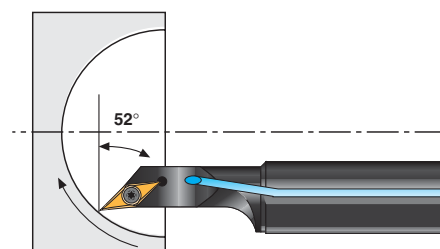
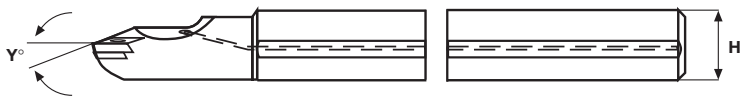
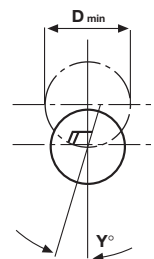
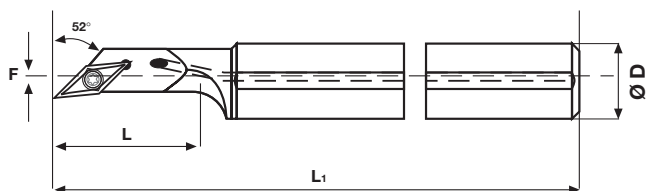
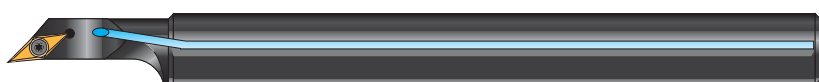
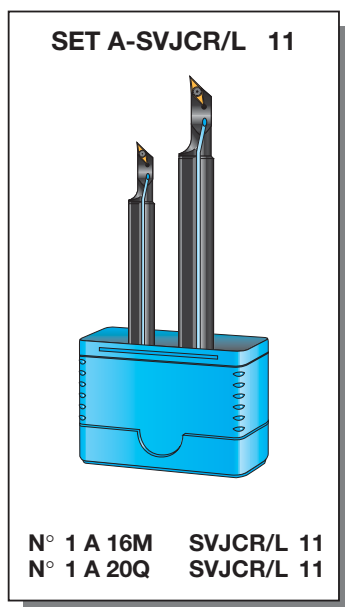

Codice d'ordine Bestell-Nr. Order No.	(mm) Dimensioni - Abmessungen - Dimensions									
	D	L	L ₁	F	D _{min}	Y°	H			
A 16M SVJCR/L 11	16	30	150	2	22	6	15	VCMT - VCGT 1103 ...	VT25	BT08
A 20Q SVJCR/L 11	20	38	180	2	25	5	19	VCMT - VCGT 1103 ...	VT25	BT08
A 25R SVJCR/L 16	25	44	200	2	28	4	24	VCMT - VCGT 1604 ...	VT40	BT15

Utensili per tornitura interna

Werkzeuge fuer innenbearbeitung

Internal turning tools

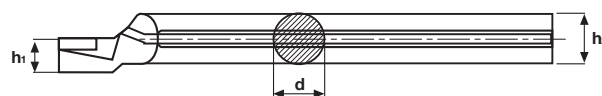
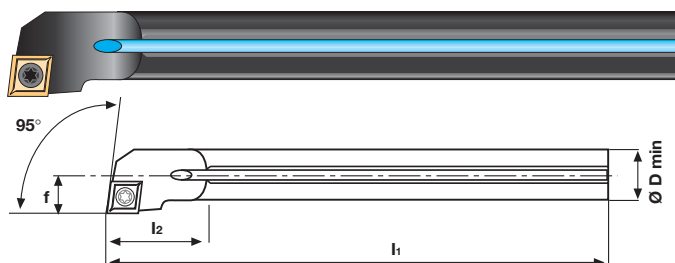

A-SCLC R/L

Stelo in acciaio con lubrificazione
 Stahlschaft mit innerer Kühlmittelzufuhr
 Steel shank with inner coolant supply

Codice d'ordine Bestell-Nr. Order No.	(mm) Dimensioni - Abmessungen - Dimensions							
	d	f	l ₁	l ₂	h ₁	h ₂	D _{min}	
A 08H SCLCR/L 06	8	6	100	12	3,5	7,0	12,0	CCMT-CCGT 0602...
A 10K SCLCR/L 06	10	7	125	16	4,5	9,0	14,0	
A 12L SCLCR/L 06	12	9	140	20	5,5	11,0	18,0	
A 16Q SCLCR/L 09	16	11	180	25	7,0	14,0	22,0	CCMT-CCGT 09T3...
A 20R SCLCR/L 09	20	13	200	32	9,0	18,0	26,0	
A 25R SCLCR/L 12	25	17	200	40	11,5	23,0	34,0	CCMT-CCGT 1204... US1221 GBS1221
A 32S SCLCR/L 12	32	22	250	22	16,0	31,0	40,0	
A 40T SCLCR/L 12	40	27	300	22	20,0	38,5	49,0	CCMT-CCGT 1204... US1221 GBS1221 SS1221 KS1115

E-SCLC R/L



Stelo in metallo duro con lubrificazione
 Vollhartmetallschaft mit innerer Kühlmittelzufuhr
 Solid carbide shank with inner coolant supply

Codice d'ordine Bestell-Nr. Order No.	(mm) Dimensioni - Abmessungen - Dimensions							
	d	f	l ₁	l ₂	h ₁	h ₂	D _{min}	
E 08K SCLCR/L 06	8	5	125	-	3,5	7,5	11,0	CCMT-CCGT 0602...
E 10K SCLCR/L 06	10	6	125	10	4,5	9,5	14,0	
E 12M SCLCR/L 06	12	8	150	10	5,5	11,5	17,0	
E 16R SCLCR/L 09	16	10	200	16	7,0	15,5	21,0	CCMT-CCGT 09T3...
E 20S SCLCR/L 09	20	12	250	16	9,0	19,5	25,0	
E 25S SCLCR/L 12	25	17	250	16	12,5	24,0	31,5	CCMT-CCGT 1204...
E 32U SCLCR/L 12	32	22	350	22	16,0	31,0	40,0	CCMT-CCGT 1204... US1221 GBS1221 SS1221 KS1115

K-SCLC R/L



Stelo in metallo pesante con lubrificazione
 Densimetschaft mit Kühlmittelbohrung
 Densimet shank with coolant bares

Codice d'ordine Bestell-Nr. Order No.	(mm) Dimensioni - Abmessungen - Dimensions							
	d	f	l ₁	l ₂	h ₁	h ₂	D _{min}	
K 08H SCLCR/L 06	8	4,5	100	-	3,5	7,5	9	CCMT-CCGT 0602...
K 10K SCLCR/L 06	10	5,5	125	10	4,5	9,5	11	
K 12M SCLCR/L 06	12	6,5	150	10	5,5	11,5	13	
K 16R SCLCR/L 09	16	8,5	200	16	7,0	15,5	17	CCMT-CCGT 09T3...
K 20S SCLCR/L 09	20	10,5	220	16	9,0	19,5	21	

E... SCLC - Codolo in metallo duro con foro refrigerante - Hartmetallschaft mit Kühlmittelbohrung - Carbide shank with coolant bares.
 K... SCLC - Codolo in metallo pesante con foro refrigerante - Densimetschaft mit Kühlmittelbohrung - Densimet shank with coolant bares.

Utensili per tornitura interna

Werkzeuge fuer innenbearbeitung

Internal turning tools

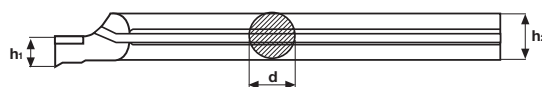
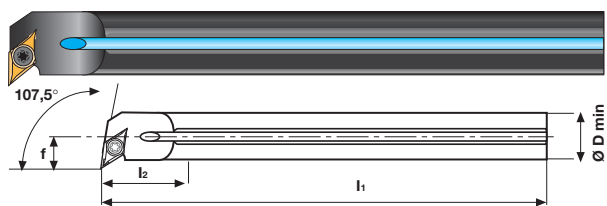

A-SDQC R/L Stelo in acciaio con lubrificazione *Stahlschaft mit innerer Kühlmittelzufuhr* Steel shank with inner coolant supply

Codice d'ordine Bestell-Nr. Order No.	(mm) Dimensioni - Abmessungen - Dimensions												
	d	f	l ₁	l ₂	h ₁	h ₂	D _{min}						
A 12L SDQCR/L 07	12	9	140	20,0	5,5	11,0	18,0	DCMT-DCGT 0702...				VT25	BT08
A 16Q SDQCR/L 07	16	11	180	25,0	7,0	14,0	22,0						
A 20R SDQCR/L 11	20	13	200	32,0	9,0	18,0	26,0	DCMT-DCGT 11T3...				VT40	BT15
A 25R SDQCR/L 11	25	17	200	40,0	11,5	23,0	34,5						
A 32S SDQCR/L 11	32	22	250	33,5	16,0	31,0	40,0	DCMT-DCGT 11T3...	US2311	GBS1111	SS1111	KS1115	
A 40T SDQCR/L 11	40	27	300	41,5	20,0	38,5	49,0						

E-SDQC R/L Stelo in metallo duro con lubrificazione *Vollhartmetallschaft mit innerer Kühlmittelzufuhr* Solid carbide shank with inner coolant supply

Codice d'ordine Bestell-Nr. Order No.	(mm) Dimensioni - Abmessungen - Dimensions												
	d	f	l ₁	l ₂	h ₁	h ₂	D _{min}						
E 10K SDQCR/L 07	10	7	125	10,0	4,5	9,0	14,0					VT25	BT08
E 12M SDQCR/L 07	12	9	150	12,5	5,5	11,0	18,0	DCMT-DCGT 0702...					
E 16R SDQCR/L 07	16	11	200	16,5	7,0	15,0	22,0						
E 20S SDQCR/L 11	20	13	250	13,0	9,0	18,0	26,0	DCMT-DCGT 11T3...				VT40	BT15
E 25S SDQCR/L 11	25	17	250	17,0	11,5	23,0	31,5						

NOVITÀ
NEU
NEW

A-SVQC R/L Stelo in acciaio con lubrificazione *Stahlschaft mit innerer Kühlmittelzufuhr* Steel shank with inner coolant supply

Codice d'ordine Bestell-Nr. Order No.	(mm) Dimensioni - Abmessungen - Dimensions												
	d	f	l ₁	l ₂	h ₁	h ₂	D _{min}						
A 25R SVQCR/L 16	25	17	200	40,0	11,5	23,0	32,0	VCMT-VCMT 1604...				VT40	BT15

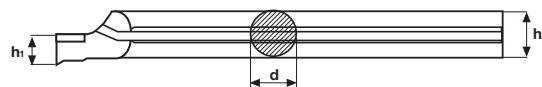
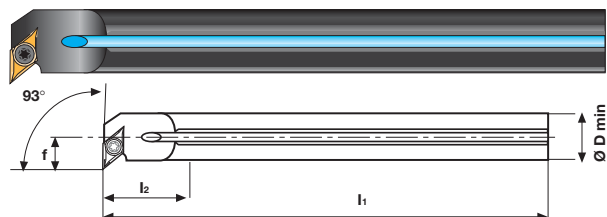

A-SDUC R/L Stelo in acciaio con lubrificazione *Stahlschaft mit innerer Kühlmittelzufuhr* Steel shank with inner coolant supply

Codice d'ordine Bestell-Nr. Order No.	(mm) Dimensioni - Abmessungen - Dimensions												
	d	f	l ₁	l ₂	h ₁	h ₂	D _{min}						
A 12K SDUCR/L 07	12	9	140	20,0	5,5	11,0	18,0	DCMT-DCGT 0702...				VT25	BT08
A 16Q SDUCR/L 07	16	11	180	25,0	7,0	14,0	22,0						
A 20R SDUCR/L 11	20	13	200	32,0	9,0	18,0	26,0	DCMT-DCGT 11T3...				VT40	BT15
A 25R SDUCR/L 11	25	17	200	40,0	11,5	23,0	34,0						
A 32S SDUCR/L 11	32	22	250	50,0	16,0	31,0	40,0	DCMT-DCGT 11T3...	US2311	GBS1111	SS1111	KS1115	
A 40T SDUCR/L 11	40	27	300	33,0	20,0	38,5	49,0						

E-SDUC R/L Stelo in metallo duro con lubrificazione *Vollhartmetallschaft mit innerer Kühlmittelzufuhr* Solid carbide shank with inner coolant supply

Codice d'ordine Bestell-Nr. Order No.	(mm) Dimensioni - Abmessungen - Dimensions												
	d	f	l ₁	l ₂	h ₁	h ₂	D _{min}						
E 10K SDUCR/L 07	10	7	125	10,0	4,5	9,5	14,0					VT25	BT08
E 12M SDUCR/L 07	12	9	150	12,5	5,5	11,5	18,0	DCMT-DCGT 0702...					
E 16R SDUCR/L 11	16	11	200	16,5	7,0	15,5	22,0						
E 20S SDUCR/L 11	20	13	250	20,5	9,0	19,0	26,0	DCMT-DCGT 11T3...				VT40	BT15
E 25S SDUCR/L 11	25	17	250	26,0	11,5	24,0	31,5	DCMT-DCGT 11T3...	US2311	GBS1111	SS1111	KS1115	

E... SCLC - Codolo in metallo duro con foro refrigerante - Hartmetallschaft mit Kühlmittelbohrung - Carbide shank with coolant bores.

K... SCLC - Codolo in metallo pesante con foro refrigerante - Densimetschaft mit Kühlmittelbohrung - Densimet shank with coolant bores.

Utensili per tornitura interna

Werkzeuge fuer innenbearbeitung

Internal turning tools

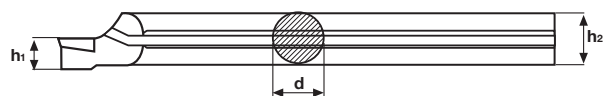
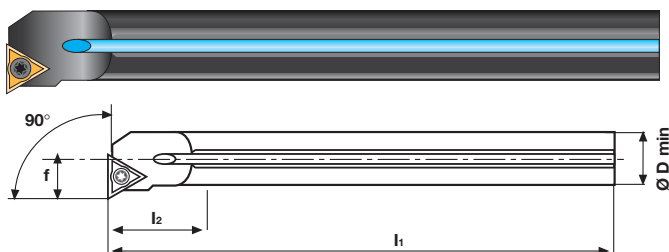

A-STFC R/L Stelo in acciaio con lubrificazione *Stahlschaft mit innerer Kühlmittelzufuhr* Steel shank with inner coolant supply

Codice d'ordine Bestell-Nr. Order No.	(mm) Dimensioni - Abmessungen - Dimensions											
	d	f	l ₁	l ₂	h ₁	h ₂	D _{min}					
A 10K STFCR/L 11	10	7	125	16	4,5	9,0	14,0	TCMT-TCGT 1102...			VT25	BT08
A 12L STFCR/L 11	12	9	140	20	5,5	11,0	18,0					
A 16Q STFCR/L 11	16	11	180	25	7,0	14,0	22,0					
A 20R STFCR/L 16	20	13	200	32	9,0	18,0	26,0	TCMT-TCGT 16T3...			VT40	BT15
A 25R STFCR/L 16	25	17	200	40	11,5	23,0	34,0					
A 32S STFCR/L 16	32	22	250	21	16,0	31,0	40,0	TCMT-TCGT 16T3...	US5511	GBS1111	SS1111	KS1115
A 40T STFCR/L 16	40	27	300	21	20,0	38,5	49,0					

E-STFC R/L Stelo in metallo duro con lubrificazione *Vollhartmetallschaft mit innerer Kühlmittelzufuhr* Solid carbide shank with inner coolant supply

Codice d'ordine Bestell-Nr. Order No.	(mm) Dimensioni - Abmessungen - Dimensions											
	d	f	l ₁	l ₂	h ₁	h ₂	D _{min}					
E 12M STFCR/L 11	12	9	150	20,0	5,5	11,0	17,0	TCMT-TCGT 1102...			VT25	BT08
E 16Q STFCR/L 11	16	11	180	25,0	7,0	14,0	21,0					
E 20S STFCR/L 11	20	13	250	32,0	9,0	18,0	25,0					
E 25S STFCR/L 16	25	17	250	40,0	11,5	23,0	31,5	TCMT-TCGT 16T3...			VT40	BT15

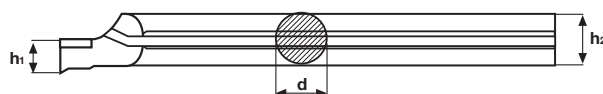
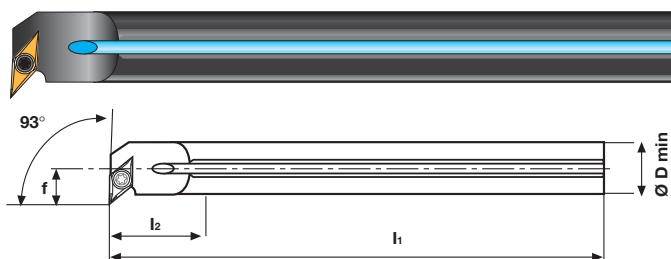

A-SVUC R/L Stelo in acciaio con lubrificazione *Stahlschaft mit innerer Kühlmittelzufuhr* Steel shank with inner coolant supply

Codice d'ordine Bestell-Nr. Order No.	(mm) Dimensioni - Abmessungen - Dimensions											
	d	f	l ₁	l ₂	h ₁	h ₂	D _{min}					
A 16M SVUCR/L 11	16	11	150	16,5	8,0	15,5	21,0	VCMT-VCGT 1103...			VT25	BT08
A 20Q SVUCR/L 11	20	13	180	20,5	10,0	19,0	25,0					
A 25R SVUCR/L 11	25	17	200	25,5	12,5	24,0	31,5					
A 32S SVUCR/L 16	32	22	250	33,5	16,0	31,0	40,0	VCMT-VCGT 1604...	US6522	GBS1111	SS1111	KS1115
A 40T SVUCR/L 16	40	27	300	40,0	20,0	38,5	49,0					

E-SVUC R/L Stelo in metallo duro con lubrificazione *Vollhartmetallschaft mit innerer Kühlmittelzufuhr* Solid carbide shank with inner coolant supply

Codice d'ordine Bestell-Nr. Order No.	(mm) Dimensioni - Abmessungen - Dimensions									
	d	f	L ₁	L ₂	h ₁	h ₂	D _{min}			
E 16R SVUCR/L 11	16	11	200	16,5	8,0	15,5	21,0	VCMT-VCGT 1103...	VT25	BT08
E 20S SVUCR/L 11	20	13	250	20,5	10,0	19,0	25,0			
E 25S SVUCR/L 11	25	17	250	25,5	12,5	24,0	31,5			

E... SCLC - Codolo in metallo duro con foro refrigerante - Hartmetallschaft mit Kühlmittelbohrung - Carbide shank with coolant bores.

K... SCLC - Codolo in metallo pesante con foro refrigerante - Densimetschaft mit Kühlmittelbohrung - Densimet shank with coolant bores.

Utensili per tornitura esterna

Werkzeuge fuer aussenbearbeitung
External turning tools

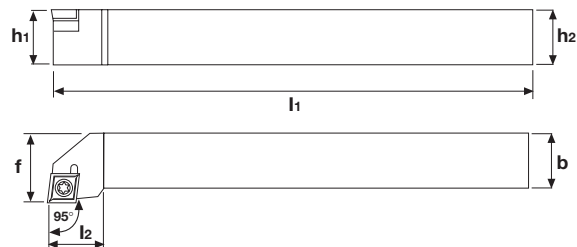
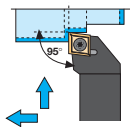

SCLC R/L Stelo in acciaio *Stahlschaft* Steel shank

Codice d'ordine Bestell-Nr. Order No.	(mm) Dimensioni - Abmessungen - Dimensions										
	h ₁	h ₂	b	l ₁	l ₂	f					
SCLCR/L 0808 D06	8	8	8	60	9	10	CCMT-CCGT 0602...			SS1751	KS1751
SCLCR/L 1010 E06	10	10	10	70	9	12				SS1111	KS1111
SCLCR/L 1212 F09	12	12	12	80	15	16	CCMT-CCGT 09T3...			SS1111	KS1111
SCLCR/L 1616 H09	16	16	16	100	17	20	CCMT-CCGT 09T3...	US1111	GBS1111	SS1111	KS1115
SCLCR/L 2020 K09	20	20	20	125	17	25					
SCLCR/L 1616 H12	16	16	16	100	20	20					
SCLCR/L 2020 K12	20	20	20	125	20	25	CCMT-CCGT 1204...	US1221	GBS1221	SS1221	KS1115
SCLCR/L 2525 M12	25	25	25	150	20	32					

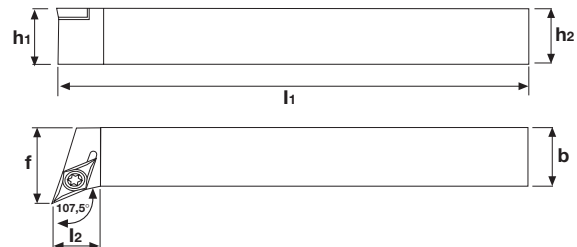
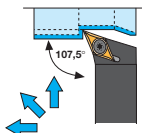

SDHC R/L Stelo in acciaio *Stahlschaft* Steel shank

Codice d'ordine Bestell-Nr. Order No.	(mm) Dimensioni - Abmessungen - Dimensions										
	h ₁	h ₂	b	l ₁	l ₂	f					
SDHCR/L 1010 E07	10	10	10	70	5,5	12	DCMT-DCGT 0702...			SS1751	KS1751
SDHCR/L 1212 F07	12	12	12	80	12,0	16					
SDHCR/L 1616 H11	16	16	16	100	10,4	20	DCMT-DCGT 11T3...	US2311	GBS1111	SS1111	KS1115
SDHCR/L 2020 K11	20	20	20	125	14,0	25					
SDHCR/L 2525 M11	25	25	25	150	20,0	32					

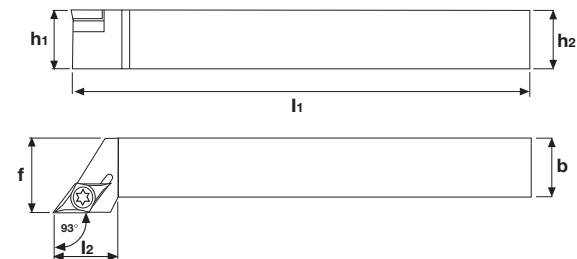
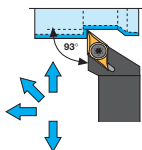

SDJC R/L Stelo in acciaio *Stahlschaft* Steel shank

Codice d'ordine Bestell-Nr. Order No.	(mm) Dimensioni - Abmessungen - Dimensions										
	h ₁	h ₂	b	l ₁	l ₂	f					
SDJCR/L 0808 D07	8	8	8	60	13,0	10	DCMT-DCGT 0702...			SS1751	KS1751
SDJCR/L 1010 E07	10	10	10	70	13,0	12					
SDJCR/L 1212 F07	12	12	12	80	14,5	16					
SDJCR/L 1616 H11	16	16	16	100	20,0	20	DCMT-DCGT 11T3...	US2311	GBS1111	SS1111	KS1115
SDJCR/L 2020 K11	20	20	20	125	20,5	25					
SDJCR/L 2525 M11	25	25	25	150	21,5	32					

Utensili per tornitura esterna

Werkzeuge fuer aussenbearbeitung
External turning tools

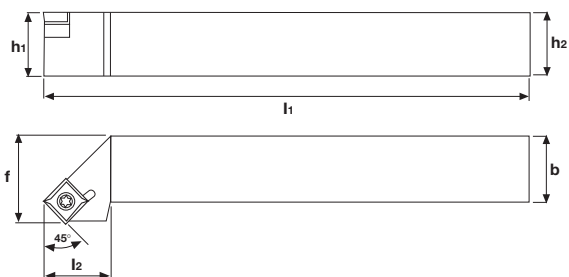
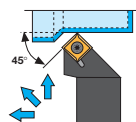

SSSC R/L Stelo in acciaio *Stahlschaft* Steel shank

Codice d'ordine Bestell-Nr. Order No.	(mm) Dimensioni - Abmessungen - Dimensions										
	h ₁	h ₂	b	l ₁	l ₂	f					
SSSCR/L 1212 F09	12	12	12	80	18	16	SCMT-SCGT 09T3...			SS1111	KS1111
SSSCR/L 1616 H09	16	16	16	100	20	20	SCMT-SCGT 09T3...	US4111	GBS1111	SS1111	KS1115
SSSCR/L 2020 K09	20	20	20	125	20	25					
SSSCR/L 1616 H12	16	16	16	100	25	20	SCMT-SCGT 1204...	US4221	GBS1221	SS1221	KS1115
SSSCR/L 2020 K12	20	20	20	125	25	25					
SSSCR/L 2525 M12	25	25	25	150	25	32					

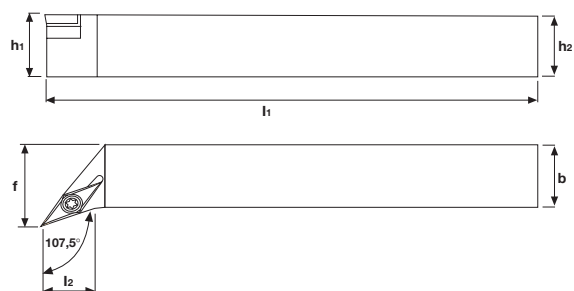
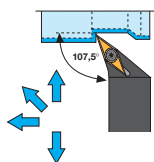

SVHC R/L Stelo in acciaio *Stahlschaft* Steel shank

Codice d'ordine Bestell-Nr. Order No.	(mm) Dimensioni - Abmessungen - Dimensions										
	h ₁	h ₂	b	l ₁	l ₂	f					
SVHCR/L 1212 F11	12	12	12	80	11,4	16	VCMT-VC GT 1103...			SS1751	KS1715
SVHCR/L 1616 H11	16	16	16	100	11,4	20					
SVHCR/L 2020 K11	20	20	20	125	14,6	25					
SVHCR/L 2525 M11	25	25	25	150	20,9	32	VCMT-VC GT 1604...	US6522	GBS1111	SS1111	KS1115
SVHCR/L 2020 K16	20	20	20	125	13,2	25					
SVHCR/L 2525 M16	25	25	25	150	19,6	32					

Utensili per tornitura esterna

Werkzeuge fuer aussenbearbeitung
External turning tools

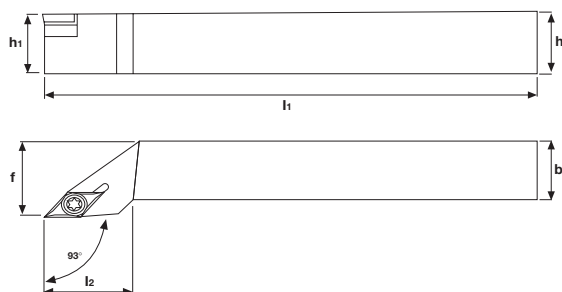
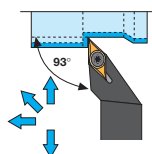

SVJCR R/L Stelo in acciaio *Stahlschaft* Steel shank

Codice d'ordine Bestell-Nr. Order No.	(mm) Dimensioni - Abmessungen - Dimensions										
	h ₁	h ₂	b	l ₁	l ₂	f					
SVJCR/L 1212 F11	12	12	12	80	21,5	16	VCMT-VC GT 1103...			SS1751	KS1751
SVJCR/L 1616 H11	16	16	16	100	21,5	20					
SVJCR/L 2020 K11	20	20	20	125	23,0	25					
SVJCR/L 2525 M11	25	25	25	150	25,5	32	VCMT-VC GT 1604...	US6522	GBS1111	SS1111	KS1115
SVJCR/L 2020 K16	20	20	20	125	29,5	25					
SVJCR/L 2525 M16	25	25	25	150	32,5	32					

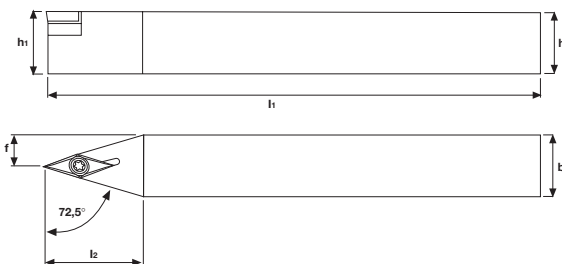
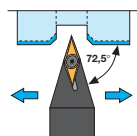

SVVC N Stelo in acciaio *Stahlschaft* Steel shank



Codice d'ordine Bestell-Nr. Order No.	(mm) Dimensioni - Abmessungen - Dimensions										
	h ₁	h ₂	b	l ₁	l ₂	f					
SVVC N 1212 F11	12	12	12	80	19	6,0	VCMT-VC GT 1103...			SS1751	KS1751
SVVC N 1616 H11	16	16	16	100	25	8,0					
SVVC N 2020 K11	20	20	20	125	32	10,0					
SVVC N 2525 M11	25	25	25	150	40	12,5	VCMT-VC GT 1604...	US6522	GBS1111	SS1111	KS1115
SVVC N 2020 K16	20	20	20	125	32	10,0					
SVVC N 2525 M16	25	25	25	150	40	12,5					

Utensili per tornitura interna

Werkzeuge fuer innenbearbeitung

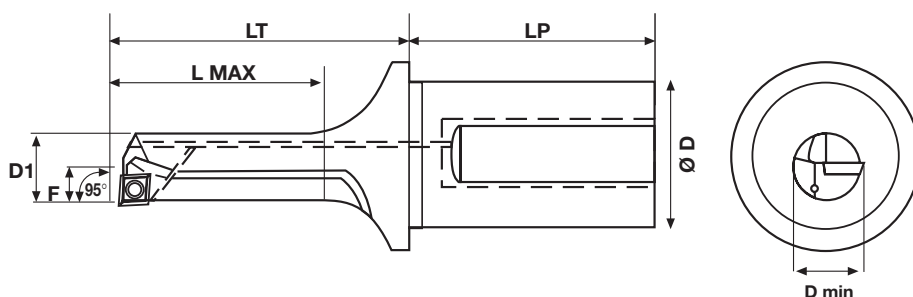
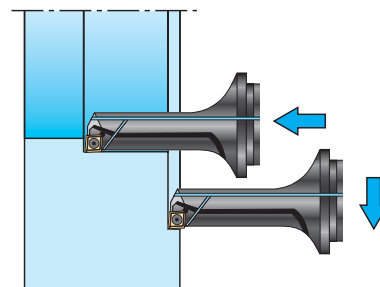
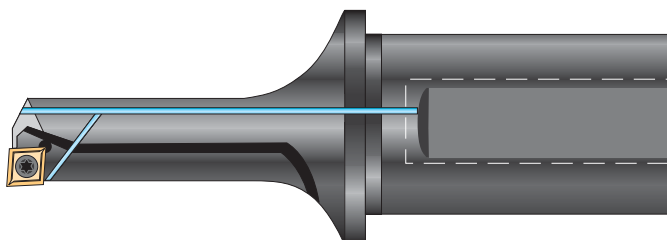
Internal turning tools



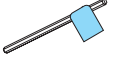

Codice d'ordine Bestell-Nr. Order No.	(mm) Dimensioni - Abmessungen - Dimensions									
	D1	F	Dmin	D	LP	LT	L MAX			
BIG 25 - SCLCR/L - 0815 - 06	8	4,5	9	25	45	37	15	CCMT 0602 ... CCGT 0602 ...	VT25	BT08
BIG 25 - SCLCR/L - 0820 - 06						42	20			
BIG 25 - SCLCR/L - 1015 - 06						37	15			
BIG 25 - SCLCR/L - 1020 - 06	42	20								
BIG 25 - SCLCR/L - 1025 - 06	47	25								
BIG 25 - SCLCR/L - 1215 - 06	12	6,5	13			37	15			
BIG 25 - SCLCR/L - 1220 - 06						42	20			
BIG 25 - SCLCR/L - 1230 - 06						52	30			
BIG 25 - SCLCR/L - 1420 - 06	14	7,5	15			42	20			
BIG 25 - SCLCR/L - 1430 - 06						52	30			
BIG 25 - SCLCR/L - 1440 - 06						62	40			
BIG 25 - SCLCR/L - 1625 - 09	16	8,5	17			47	25			
BIG 25 - SCLCR/L - 1635 - 09						57	35			
BIG 25 - SCLCR/L - 1650 - 09						72	50			
BIG 25 - SCLCR/L - 2030 - 09	20	10,5	21			52	30			
BIG 25 - SCLCR/L - 2040 - 09				62	40					
BIG 25 - SCLCR/L - 2060 - 09				82	60					
BIG 25 - SCLCR/L - 2550 - 09	25	13	26	72	50					
BIG 25 - SCLCR/L - 2570 - 09				92	70					
BIG 32 - SCLCR/L - 1030 - 06	10	5,5	11	32	58	52	30	CCMT 0602 ... CCGT 0602 ...	VT25	BT08
BIG 32 - SCLCR/L - 1040 - 06						62	40			
BIG 32 - SCLCR/L - 1240 - 06						62	40			
BIG 32 - SCLCR/L - 1250 - 06	72	50								
BIG 32 - SCLCR/L - 1450 - 06	14	7,5	15			72	50			
BIG 32 - SCLCR/L - 1460 - 06						82	60			
BIG 32 - SCLCR/L - 1660 - 09						82	60			
BIG 32 - SCLCR/L - 1670 - 09	16	8,5	17			92	70			
BIG 32 - SCLCR/L - 2070 - 09						92	70			
BIG 32 - SCLCR/L - 2080 - 09						102	80			
BIG 32 - SCLCR/L - 2580 - 09	25	13	26			102	80			
BIG 32 - SCLCR/L - 2590 - 09						112	90			
BIG 32 - SCLCR/L - 2590 - 09	25	13	26			102	80			
BIG 32 - SCLCR/L - 2590 - 09						112	90			

Utensili per tornitura interna

Werkzeuge fuer innenbearbeitung

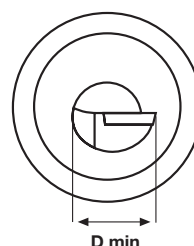
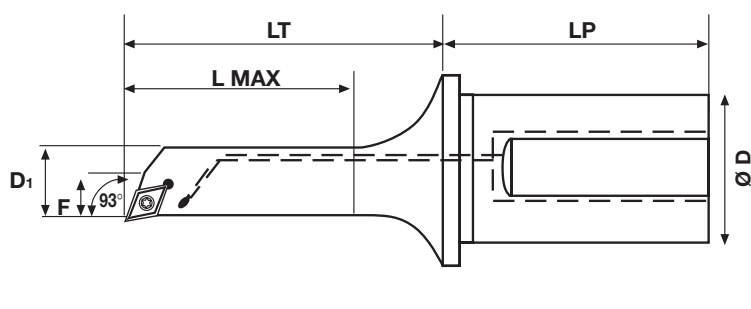
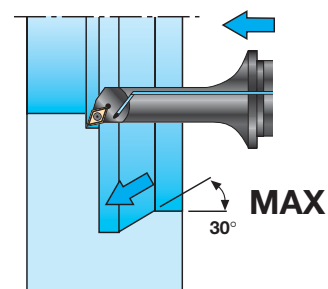
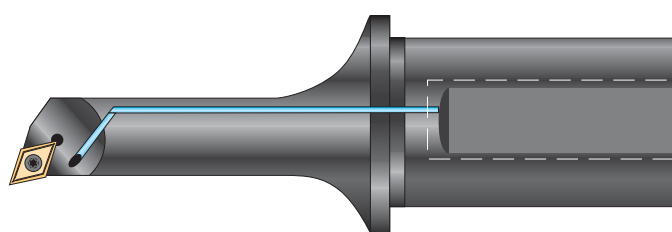
Internal turning tools

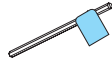

Codice d'ordine Bestell-Nr. Order No.	(mm) Dimensioni - Abmessungen - Dimensions									
	D1	F	Dmin	D	LP	LT	L MAX			
BIG 25 - SDUCR/L - 1015 - 07	10	7	14	25	45	37	15	DCMT 0702 ... DCGT 0702 ...	VT25	BT08
BIG 25 - SDUCR/L - 1020 - 07						42	20			
BIG 25 - SDUCR/L - 1030 - 07						52	30			
BIG 25 - SDUCR/L - 1215 - 07	12	9	18			37	15			
BIG 25 - SDUCR/L - 1220 - 07						42	20			
BIG 25 - SDUCR/L - 1230 - 07						52	30			
BIG 25 - SDUCR/L - 1625 - 07	16	11	22			47	25			
BIG 25 - SDUCR/L - 1635 - 07						57	35			
BIG 25 - SDUCR/L - 1650 - 07						72	50			
BIG 25 - SDUCR/L - 2030 - 11	20	13	26			52	30			
BIG 25 - SDUCR/L - 2040 - 11						62	40			
BIG 25 - SDUCR/L - 2060 - 11						82	60			
BIG 25 - SDUCR/L - 2550 - 11	25	17	34	72	50					
BIG 25 - SDUCR/L - 2570 - 11				92	70					
BIG 32 - SDUCR/L - 1040 - 07	10	7	14	32	58	62	40	DCMT 0702 ... DCGT 0702 ...	VT25	BT08
BIG 32 - SDUCR/L - 1245 - 07	12	9	18			67	45			
BIG 32 - SDUCR/L - 1660 - 07	16	11	22			82	60			
BIG 32 - SDUCR/L - 2070 - 11	20	13	26			92	70			
BIG 32 - SDUCR/L - 2580 - 11	25	17	34			102	80			

Utensili per taglio e scanalatura esterna

Aussenbearbeitung Radial - Stechdrehen

External machining Radial grooving

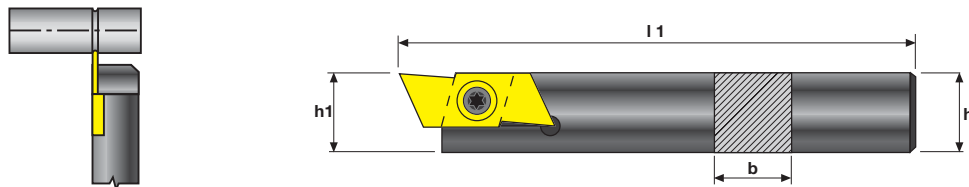

Codice d'ordine Bestell-Nr. Order No.	(mm) Dimensioni - Abmessungen - Dimensions						
	h1	h	b	l1			
THE - 7 - 0808 R / L	08	08	08	100	GIE..GP-ST-SG-GR-GW	VT 30-G	BT 08
THE - 7 - 1010 R / L	10	10	10	120			
THE - 7 - 1212 R / L	12	12	12	120			
THE - 7 - 1616 R / L	16	16	16	120			
THE - 7 - 2020 R / L	20	20	20	120			
THE - 7 - 2525 R / L	25	25	25	120			
Utensili per macchine svizzere							
THS - 7 - 0808 R / L	08	08	08	140	GIE..GP-ST-SG-GR-GW	VT 30-G	BT 08
THS - 7 - 1010 R / L	10	10	10	150			

Utensili per scanalatura interna

Innenbearbeitung Innenstechdrehen

Internal machining Internal grooving

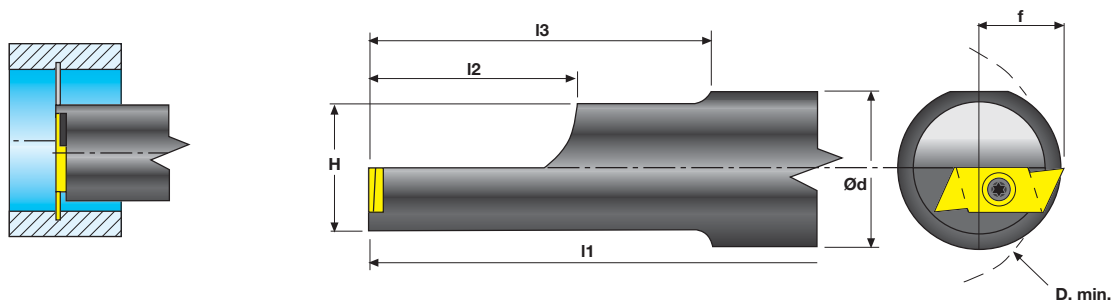

Codice d'ordine Bestell-Nr. Order No.	(mm) Dimensioni - Abmessungen - Dimensions									
	ØD	ød	f	H	l1	l2	l3			
THI - 7 - 20 R / L	38,10	20	13,34	19,05	140	25	50	GIE..GP-ST-SG-GR-GW	VT 30-G	BT 08
THI - 7 - 25 R / L	38,10	25	13,34	19,05	150	32	63			
THI - 7 - 32 R / L	38,10	32	13,34	19,05	150	32	63			

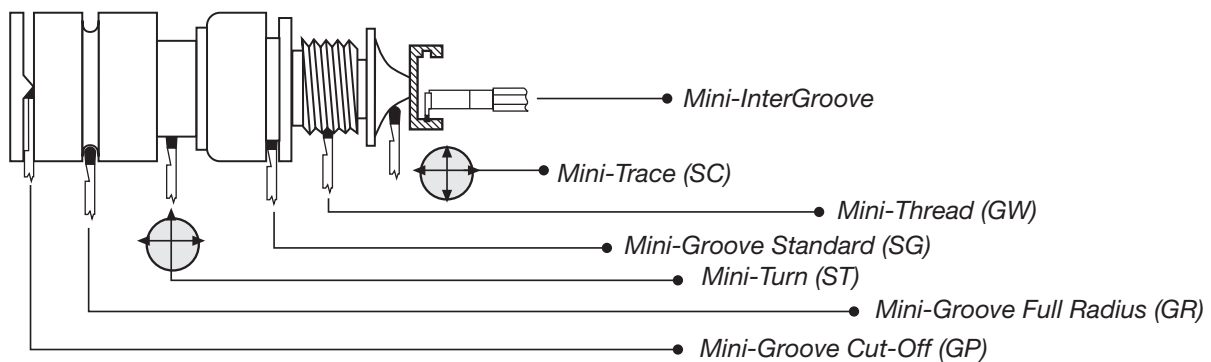

NOTE: - per utensili destri (R) inserto sinistro (L) - per utensili sinistri (L) inserto destro (R)

NOTE: - fuer rechthande werkzeuge (R) Linke W.P. (L) - fuer lin kehande werkzeuge (L) Rechte W.P. (R)

NOTE: - right handed holders (R) Left hand inserts (L) - Left hand holders (L) right hand inserts (R)

Inserti

Wendepatte

Insert

Inserti per scanalatura e taglio - Drehen und Stechen - Grooving and Turning

Inserto
Wendepatte
Insert

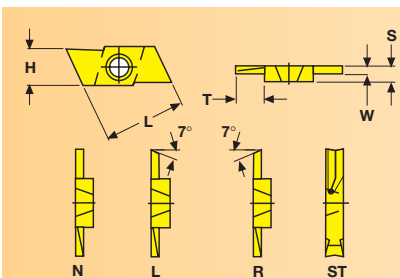

articolo	W ^{+0,02} ₋₀	T	H	S	L
GIE-7-GP-1,0 R/L N	1,0	6,0	7	2	17
GIE-7-GP-1,0 R/L R/L	1,0	6,0	7	2	17
GIE-7-GP-1,5 R/L N	1,5	6,0	7	2	17
GIE-7-GP-1,5 R/L R/L	1,5	6,0	7	2	17
GIE-7-GP-2,0 R/L N	2,0	6,0	7	2	17
GIE-7-GP-2,0 R/L R/L	2,0	6,0	7	2	17
GIE-7-ST-3,0 R/L	3,17	6,0	7	3,17	17

Inserti per scanalatura per anelli - Stechen - Grooving

Inserto
Wendepatte
Insert

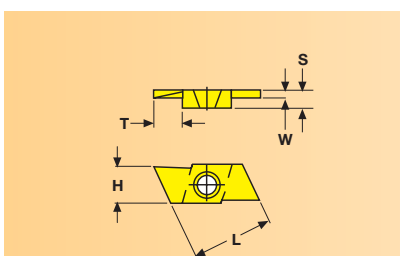

articolo	W ^{+0,02} ₋₀	T	H	S	L
GIE-7-SG-0,5 R/L	0,5	2,54	7	2	17
GIE-7-SG-0,7 R/L	0,7	2,54	7	2	17
GIE-7-SG-0,8 R/L	0,8	2,54	7	2	17
GIE-7-SG-0,9 R/L	0,9	2,54	7	2	17
GIE-7-SG-1,1 R/L	1,1	6,0	7	2	17
GIE-7-SG-1,3 R/L	1,3	6,0	7	2	17
GIE-7-SG-1,6 R/L	1,6	6,0	7	2	17
GIE-7-SG-1,85 R/L	1,85	6,0	7	2	17

Inserti per scanalatura raggiata e profilatura - Vollradiusausführung - Full radius execution

Inserto
Wendepatte
Insert

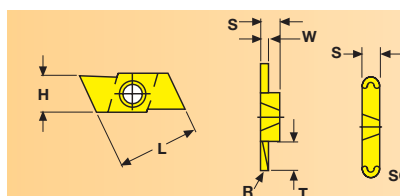

articolo	W ^{+0,02} ₋₀	R	T	H	S	L
GIE-7-GR-1,0 R/L	1,0	0,5	6,0	7	2	17
GIE-7-GR-1,5 R/L	1,5	0,75	6,0	7	2	17
GIE-7-GR-2,0 R/L	2,0	1,0	6,0	7	2	17
GIE-7-SC-3,0 R/L	3,17	1,585	6,0	7	3,17	17

Inserti per filettare - Gewindedrehen - Threading

Inserto
Wendepatte
Insert

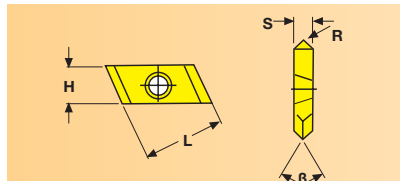

articolo	β	R	H	S	L
GIE-7-GW-60 R/L	60°	0,1	7	2	17
GIE-7-GW-55 R/L	55°	0,12	7	2	17

SET MINI GROOVE

Codice d'ordine
Bestell-Nr.
Order No.

SET-05-GIE

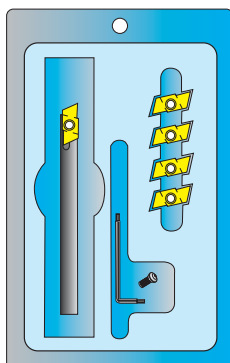

Contenuto del Set - Inhalt pro Set - Set Contents

N° 1 UTENSILE THE - 7 - 1212 - R
N° 1 INSERTO GIE - 7 - SG - 0,9 L TIN
N° 1 INSERTO GIE - 7 - SG - 1,1 L TIN
N° 1 INSERTO GIE - 7 - SG - 1,3 L TIN
N° 1 INSERTO GIE - 7 - SG - 1,6 L TIN
N° 1 INSERTO GIE - 7 - SG - 1,85 L TIN

(*) SG = scanalatura standard GP = scanalatura e taglio GR = scanalatura raggiata GW = filettatura ST = tornitura SC = profilatura
SG = standard grooving GP = grooving and cutoff GR = grooving full radius GW = threading ST = turning SC = tracing

