



T O O L I N G

MOULDMILL



# Frese a copiare - modulare

## Threaded type milling cutters

### Einschraubkugelgesenkfräser

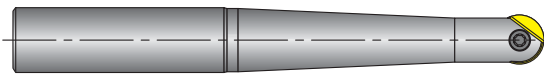

Art. **200 C**

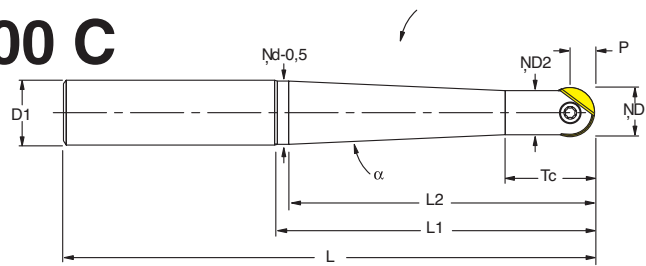

**Ricambi**  
Spare parts  
Ersatzteile

Codice d'ordine Order No. Bestell-Nr.	(mm) Dimensioni - Dimension - Abmessungen									Vite Screw Schraube	Chiave Key Schlüssel	Inserto Insert Wendeplatte
	D	L	L1	L2	P	D2	D1	Tc	$\alpha$			
200C 08 35 12	8	92	35	-	4	6,5	12	19	9°	PR 08	CT 07	RA 08
200C 08 53 12	8	110	53	48	4	6,5	12	19	4,3°	PR 08	CT 07	RA 08
200C 08 75 12	8	132	75	70	4	6,5	12	19	2,6°	PR 08	CT 07	RA 08
200C 10 35 12	10	92	35	-	5	8	12	22	7,5°	PR 10	CT 08	RA 10
200C 10 53 12	10	110	53	48	5	8	12	22	3,2°	PR 10	CT 08	RA 10
200C 10 75 12	10	132	75	70	5	8	12	22	1,9°	PR 10	CT 08	RA 10
200C 12 85 16	12	145	85	80	6	10	16	22	2,5°	PR 12	CT 10	RA 12
200C 16 100 20	16	166	100	95	8	14	20	28	2,2°	PR 16	CT 15	RA 16
200C 20 115 25	20	191	115	110	10	17,2	25	34	2,6°	PR 20	CT 20	RA 20
200C 25 135 32	25	215	135	130	12,5	21,2	32	41	3,2°	PR 25	CT 30	RA 25

Art. **200 MO**

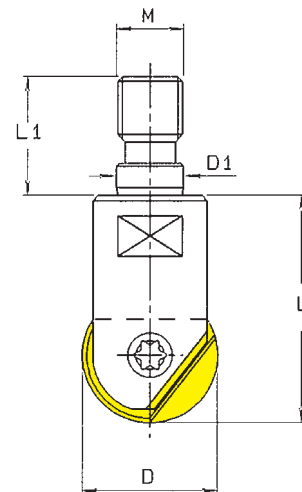

**Ricambi**  
Spare parts - Ersatzteile

Codice d'ordine Order No. Bestell-Nr.	(mm) Dimensioni - Dimension - Abmessungen					Vite Screw Schraube	Chiave Key Schlüssel	Inserto Insert Wendeplatte
	D	L	D1	M	L1			
200MO-D8	8	23	6,5	M6	14,5	PR 08	CT 07	RA 08
200MO-D10	10	33	8,5	M8	17,5	PR 10	CT 08	RA 10
200MO-D12	12	33	8,5	M8	17,5	PR 12	CT 10	RA 12
200MO-D16	16	28	8,5	M8	17,5	PR 16	CT 15	RA 16
200MO-D20	20	28	10,5	M10	20	PR 20	CT 20	RA 20
200MO-D25	25	42	12,5	M12	22	PR 25	CT 30	RA 25

# Frese a copiare modulare

Threaded type milling cutters  
Einschraubfräser für Rund - WSP



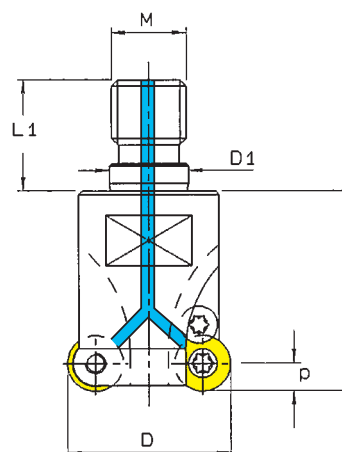

Art. **400MO**



Codice d'ordine Order No. Bestell-Nr.	(mm) Dimensioni - Dimension - Abmessungen							Inserto Insert Wendplatte
	D	L	M	D1	L1	p	z	
400MO-D10-2	10	18	M6	6,5	14,5	2,5	2	RDHX 0501 MOT
400MO-D20-5	20	30	M10	10,5	20	2,5	2	RDHX 0501 MOT
400MO-D12-2	12	18	M6	6,5	14,5	3,5	2	RDHX 07T1 MOT
400MO-D15-2	15	23	M8	8,5	17,5	3,5	2	RDHX 0702 MOT
400MO-D15-3	15	23	M8	8,5	17,5	3,5	3	RDHX 0702 MOT
400MO-D20-4	20	30	M10	10,5	20	3,5	4	RDHX 0702 MOT
400MO-D25-5	25	35	M12	12,5	22	3,5	5	RDHX 0702 MOT
400MO-D30-5	30	43	M16	17	24	3,5	5	RDHX 0702 MOT
400MO-D20-2	20	30	M10	10,5	20	5	2	RDHX 1003 MOT
400MO-D25-2	25	35	M12	12,5	22	5	2	RDHX 1003 MOT
400MO-D25-3	25	35	M12	12,5	22	5	3	RDHX 1003 MOT
400MO-D30-4	30	43	M16	17	24	5	4	RDHX 1003 MOT
400MO-D35-4	35	43	M16	17	24	5	4	RDHX 1003 MOT
400MO-D42-5	42	43	M16	17	24	5	5	RDHX 1003 MOT
400MO-D24-2	24	35	M12	12,5	22	6	2	RDHX 12T3 MOT
400MO-D35-3	35	43	M16	17	24	6	3	RDHX 12T3 MOT
400MO-D42-4	42	43	M16	17	24	6	4	RDHX 12T3 MOT
400MO-D32-2	32	43	M16	17	24	8	2	RDHX 1604 MOT

## Ricambi - Spare parts - Ersatzteile

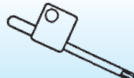
Codice d'ordine Order No. Bestell-Nr.	 Vite Screw Schraube	 Staffa Clamp Spannklaue		 Chiave Key Schlüssel
400MO-D10-2	VT 18	-	-	BT 06
400MO-D20-5	VT 18	-	-	BT 06
400MO-D12-2	VT 2530	-	-	BT 07
400MO-D15-2	VT 2530	-	-	BT 07
400MO-D15-3	VT 2530	-	-	BT 07
400MO-D20-4	VT 2530	-	-	BT 07
400MO-D25-5	VT 2530	-	-	BT 07
400MO-D30-5	VT 2530	-	-	BT 07
400MO-D20-2	VT 35	-	-	BT 15
400MO-D25-2	VT 35	-	-	BT 15
400MO-D25-3	VT 35	-	-	BT 15
400MO-D30-4	VT 35	-	-	BT 15
400MO-D35-4	VT 35	-	-	BT 15
400MO-D42-5	VT 35	-	-	BT 15
400MO-D24-2	VT 35	-	CVB 35	BT 15
400MO-D35-3	VT 35	-	CVB 35	BT 15
400MO-D42-4	VT 35	-	CVB 35	BT 15
400MO-D32-2	VT 45	CVB 45	-	BT 15

**Inserto**  
Insert  
Wendplatte

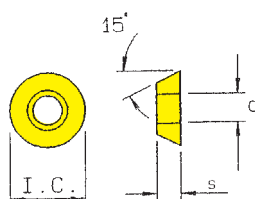

	I.C.	s	d
RDHX 0501 MOT	5	1,28	2,1
RDHX 07T1 MOT	7	1,98	2,7
RDHX 0702 MOT	7	2,38	2,7
RDHX 1003 MOT	10	3,18	3,9
RDHX 12T3 MOT	12	3,97	3,9
RDHX 1604 MOT	16	4,76	5,2

# Frese per spallamenti - modulare

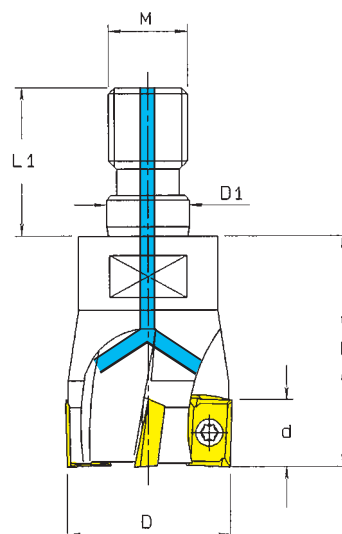
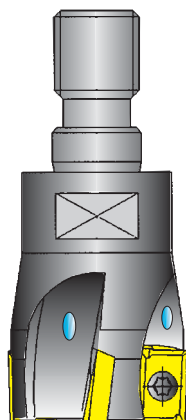

*Threaded shoulder milling cutters*  
Einschraubfräser für eck - WSP

Art. **740MO**



Codice d'ordine Order No. Bestell-Nr.	(mm) Dimensioni - Dimension - Abmessungen							Inserto Insert Wendeplatte
	D	d	L	D1	M	z	L1	
740MO-D10-1	10	10	20	6,5	M6	1	14,5	APHT APHX APKT 1003....
740MO-D12-1	12	10	20	6,5	M6	1	14,5	
740MO-D16-2	16	10	25	8,5	M8	2	17,5	
740MO-D20-3	20	10	30	10,5	M10	3	20	
740MO-D25-3	25	10	35	12,5	M12	3	22	
740MO-D25-4	25	10	35	12,5	M12	4	22	
740MO-D32-5	32	10	43	17	M16	5	24	

## Ricambi - Spare parts - Ersatzteile

Codice d'ordine Order No. Bestell-Nr.	 Vite Screw Schraube	 Chiave Key Schlüssel
740MO-D10-1	VT 25	BT 08
740MO-D12-1	VT 25	BT 08
740MO-D16-2	VT 25	BT 08
740MO-D20-3	VT 25	BT 08
740MO-D25-3	VT 25	BT 08
740MO-D25-4	VT 25	BT 08
740MO-D32-5	VT 25	BT 08

**Inserto**  
Insert  
Wendeplatte

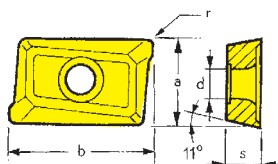

	a	b	s	d	r
APHT 1003...					
APHX 1003...	6,7	10,8	3,55	2,8	0,5
APKT 1003...					

## Adattatore in acciaio

Steel adaptors  
Stahlverlängerungen

### PC

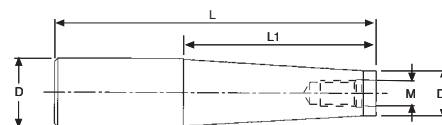

Codice d'ordine Order No. Bestell-Nr.	(mm) Dimensioni - Dimension - Abmessungen				
	D	M	L	L1	D1
PC12 060 M6	12	M6	115	60	10
PC12 080 M6	12	M6	135	80	10
PC12 100 M6	12	M6	155	100	10
PC16 080 M8	16	M8	135	80	13
PC16 100 M8	16	M8	155	100	13
PC16 120 M8	16	M8	175	120	13
PC20 100 M10	20	M10	160	100	18
PC20 140 M10	20	M10	200	140	18
PC25 100 M12	25	M12	165	100	21
PC25 150 M12	25	M12	215	150	21
PC32 100 M16	32	M16	170	100	29
PC32 150 M16	32	M16	220	150	29

### PCC

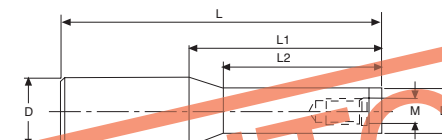
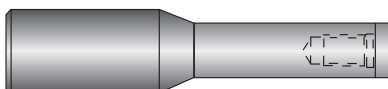

Codice d'ordine Order No. Bestell-Nr.	(mm) Dimensioni - Dimension - Abmessungen					
	D	M	L	L1	L2	D1
PCC16 025 M5	16	M5	75	25	20	8
PCC16 050 M5	16	M5	100	50	45	8
PCC16 025 M6	16	M6	80	30	25	10
PCC16 070 M6	16	M6	125	75	70	10
PCC16 025 M8	16	M8	80	30	25	13
PCC16 070 M8	16	M8	125	75	70	13
PCC20 045 M10	20	M10	100	50	45	16
PCC20 075 M10	20	M10	130	80	75	16

## Adattatore in metallo pesante

Densimet adaptors  
Schwermetallverlängerungen

### PCMD

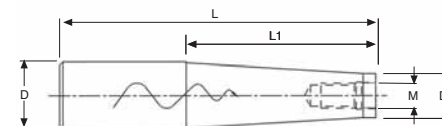
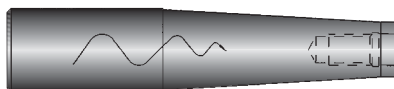

Codice d'ordine Order No. Bestell-Nr.	(mm) Dimensioni - Dimension - Abmessungen				
	D	M	L	L1	D1
PCMD12 060 M6	12	M6	115	60	10
PCMD12 080 M6	12	M6	135	80	10
PCMD16 080 M8	16	M8	140	80	13
PCMD16 120 M8	16	M8	180	120	13
PCMD20 080 M10	20	M10	140	80	18
PCMD20 120 M10	20	M10	180	120	18
PCMD25 100 M12	25	M12	170	100	21
PCMD25 140 M12	25	M12	210	140	21

# Frese a copiare

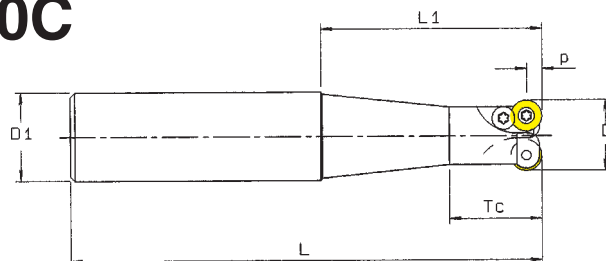

Copy milling cutters with shank  
Schafffräser für Rund - WSP

Art. **400C**



Codice d'ordine Order No. Bestell-Nr.	(mm) Dimensioni - Dimension - Abmessungen							Inserto Insert Wendepatte
	D	L1	D1	Tc	L	p	z	
400C 12 16 040	12	40	16	20	140	3,5	2	RDHX 07T1 MOT
400C 12 16 060	12	60	16	20	160	3,5	2	RDHX 07T1 MOT
400C 12 16 080	12	80	16	20	180	3,5	2	RDHX 07T1 MOT
400C 15 16 040	15	40	16	40	140	3,5	2	RDHX 0702 MOT
400C 15 16 060	15	60	16	40	160	3,5	2	RDHX 0702 MOT
400C 15 20 080	15	80	20	40	180	3,5	2	RDHX 0702 MOT
400C 15 20 100	15	100	20	40	200	3,5	2	RDHX 0702 MOT
400C 15 25 120	15	120	25	40	220	3,5	2	RDHX 0702 MOT
400C 20 20 040	20	40	20	40	140	5	2	RDHX 1003 MOT
400C 20 20 060	20	60	20	60	160	5	2	RDHX 1003 MOT
400C 20 25 080	20	80	25	60	180	5	2	RDHX 1003 MOT
400C 20 25 100	20	100	25	60	200	5	2	RDHX 1003 MOT
400C 20 25 120	20	120	25	60	220	5	2	RDHX 1003 MOT
400C 25 25 100	25	100	25	80	200	6	2	RDHX 12T3 MOT
400C 25 25 120	25	120	25	80	220	6	2	RDHX 12T3 MOT
400C 25 25 150	25	150	25	80	250	6	2	RDHX 12T3 MOT
400C 25 32 110	25	110	32	80	210	6	2	RDHX 12T3 MOT
400C 25 32 130	25	130	32	80	230	6	2	RDHX 12T3 MOT
400C 25 32 160	25	160	32	80	260	6	2	RDHX 12T3 MOT

## Ricambi - Spare parts - Ersatzteile

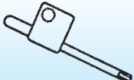
Codice d'ordine Order No. Bestell-Nr.	 Vite Screw Schraube	 Staffa Clamp Spannklaue	 Chiave Key Schlüssel
400C 12 16 040	VT 2530	-	BT 07
400C 12 16 060	VT 2530	-	BT 07
400C 12 16 080	VT 2530	-	BT 07
400C 15 16 040	VT 2530	-	BT 07
400C 15 16 060	VT 2530	-	BT 07
400C 15 20 080	VT 2530	-	BT 07
400C 15 20 100	VT 2530	-	BT 07
400C 15 25 120	VT 2530	-	BT 07
400C 20 20 040	VT 35	-	BT 15
400C 20 20 060	VT 35	-	BT 15
400C 20 25 080	VT 35	-	BT 15
400C 20 25 100	VT 35	-	BT 15
400C 20 25 120	VT 35	-	BT 15
400C 25 25 100	VT 35	CVB 35	BT 15
400C 25 25 120	VT 35	CVB 35	BT 15
400C 25 25 150	VT 35	CVB 35	BT 15
400C 25 32 110	VT 35	CVB 35	BT 15
400C 25 32 130	VT 35	CVB 35	BT 15
400C 25 32 160	VT 35	CVB 35	BT 15

**Inserto**  
Insert  
Wendepatte

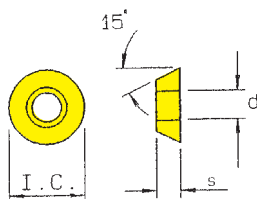

	I.C.	s	d
RDHX 07T1 MOT	7	1,98	2,7
RDHX 0702 MOT	7	2,38	2,7
RDHX 1003 MOT	10	3,18	3,9
RDHX 12T3 MOT	12	3,97	3,9

# Frese a copiare

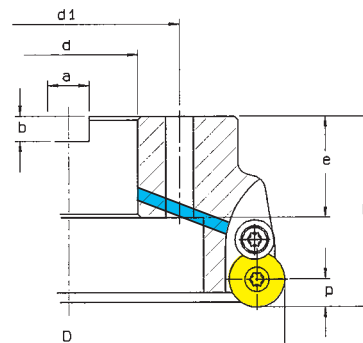
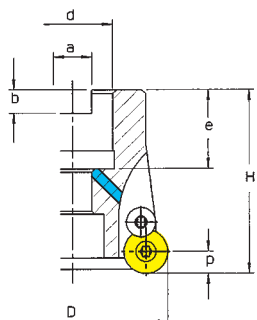
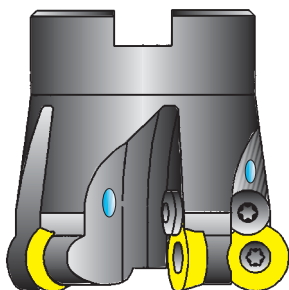

Shell copy milling cutters  
Aufsteckfräser für Rund - WSP

Art. **400M**



Codice d'ordine Order No. Bestell-Nr.	(mm) Dimensioni - Dimension - Abmessungen									Inserto Insert Wendeplatte
	D	d	d1	e	a	b	H	p	z	
400M-052-12	52	22	-	22	10,4	6,3	50	6	5	RDHX 12T3 MOT
400M-052-16	52	22	-	22	10,4	6,3	50	8	4	RDHX 1604 MOT
400M-066-12	66	27	-	28	12,4	7	50	6	6	RDHX 12T3 MOT
400M-066-16	66	27	-	28	12,4	7	50	8	5	RDHX 1604 MOT
400M-080-12	80	27	-	28	12,4	7	50	6	7	RDHX 12T3 MOT
400M-080-16	80	27	-	28	12,4	7	50	8	6	RDHX 1604 MOT
400M-100-16	100	32	-	31	14,4	8	55	8	7	RDHX 1604 MOT
400M-125-16	125	40	-	41	16,4	9	55	8	8	RDHX 1604 MOT
400M-160-16	160	40	66,7	41	16,4	9	55	8	9	RDHX 1604 MOT

## Ricambi - Spare parts - Ersatzteile

Codice d'ordine Order No. Bestell-Nr.	 Vite Screw Schraube	 Staffa Clamp Spannklaue	 Chiave Key Schlüssel	
400M-052-12	VT 35	-	CVB 35	CT 15
400M-052-16	VT 45	CVB 45	-	CT 15
400M-066-12	VT 35	-	CVB 35	CT 15
400M-066-16	VT 45	CVB 45	-	CT 15
400M-080-12	VT 35	-	CVB 35	CT 15
400M-080-16	VT 45	CVB 45	-	CT 15
400M-100-16	VT 45	CVB 45	-	CT 15
400M-125-16	VT 45	CVB 45	-	CT 15
400M-160-16	VT 45	CVB 45	-	CT 15

Inserto  
Insert  
Wendeplatte

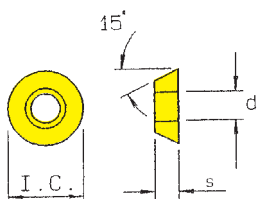

	I.C.	s	d
RDHX 12T3 MOT	12	3,97	3,9
RDHX 1604 MOT	16	4,76	5,2



# Testine in metallo duro integrale

Carbide Head Milling Cutter  
Vollhartmetall Fräskopf

Art. **400 MM**

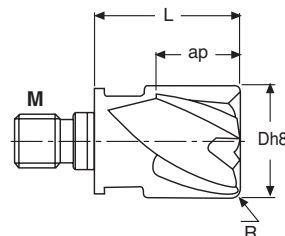
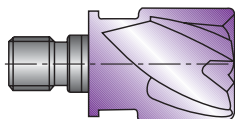

Fresa 4 tagli 45° elica positiva - Fräskopf mit 4 Schneiden 45° Spiralwinkel - Carbide Milling Head 45° - 4 flutes

Codice d'ordine Order No. Bestell-Nr.	(mm) Dimensioni - Dimension - Abmessungen					
	Z	D	ap	R	M	L
400 MM 8-4 R 0,0	4	8	10	0,0	M5	15
400 MM 8-4 R 0,5	4	8	10	0,5	M5	15
400 MM 10-4 R 0,0	4	10	10	0,0	M6	17
400 MM 10-4 R 0,5	4	10	10	0,5	M6	17
400 MM 13-4 R 0,0	4	13	12	0,0	M8	18
400 MM 13-4 R 0,5	4	13	12	0,5	M8	18
400 MM 13-4 R 1,0	4	13	12	1,0	M8	18
400 MM 16-4 R 0,0	4	16	15	0,0	M10	21
400 MM 16-4 R 0,5	4	16	15	0,5	M10	21
400 MM 16-4 R 1,0	4	16	15	1,0	M10	21
400 MM 20-4 R 0,0	4	20	19	0,0	M10	25
400 MM 20-4 R 0,5	4	20	19	0,5	M10	25
400 MM 20-4 R 1,0	4	20	19	1,0	M10	25

Metallo duro - Hartmetallsorte - Carbide grade: MTE 30 TIALN

Art. **400 MF**

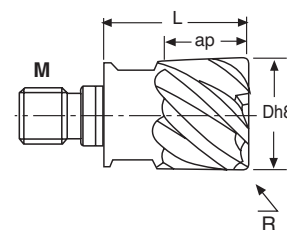
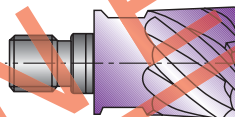

Fresa 6 tagli 45° elica positiva - Fräskopf mit 6 Schneiden 45° Spiralwinkel - Carbide Milling Head 45° - 6 flutes

Codice d'ordine Order No. Bestell-Nr.	(mm) Dimensioni - Dimension - Abmessungen					
	Z	D	ap	R	M	L
400 MF 8-6 R 0,0	6	8	10	0,0	M5	15
400 MF 8-6 R 0,5	6	8	10	0,5	M5	15
400 MF 10-6 R 0,0	6	10	10	0,0	M6	17
400 MF 10-6 R 0,5	6	10	10	0,5	M6	17
400 MF 10-6 R 1,0	6	10	10	1,0	M6	17
400 MF 10-6 R 1,5	6	10	10	1,5	M6	17
400 MF 13-6 R 0,0	6	13	12	0,0	M8	18
400 MF 13-6 R 0,5	6	13	12	0,5	M8	18
400 MF 13-6 R 1,0	6	13	12	1,0	M8	18
400 MF 13-6 R 1,5	6	13	12	1,5	M8	18
400 MF 16-6 R 0,0	6	16	15	0,0	M10	21
400 MF 16-6 R 1,0	6	16	15	1,0	M10	21

Metallo duro - Hartmetallsorte - Carbide grade: MTE 30 TIALN



# Testine in metallo duro integrale

## Carbide Head Milling Cutter

### Vollhartmetall Fräskopf

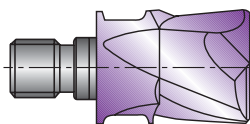

Art. **400 MA**

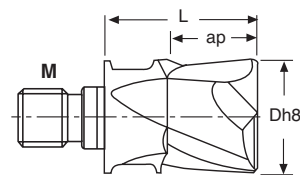

Fresa 3 tagli per alluminio - Fräskopf mit 3 Schneiden für ALU - Carbide Milling Head 3 flutes for ALU.

Codice d'ordine Order No. Bestell-Nr.	(mm) Dimensioni - Dimension - Abmessungen					
	Z	D	ap	R	M	L
400 MA 10-2 M6	2	10	10		M6	17
400 MA 13-2 M8	2	13	12		M8	18
400 MA 16-2 M10	2	16	15		M10	21

Metallo duro - Hartmetallsorte - Carbide grade: MTE 30 TIALN

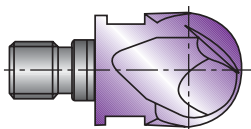

Art. **200 MKR**

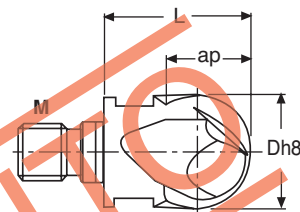

Fresa radiale 4 tagli - Radien Fräskopf mit 4 Schneiden - Radial Carbide Milling Head 4 flutes

Codice d'ordine Order No. Bestell-Nr.	(mm) Dimensioni - Dimension - Abmessungen					
	Z	D	ap	R	M	L
200 MKR 8-4	4	8	10		M5	15
200 MKR 10-4	4	10	10		M6	16
200 MKR 13-4	4	13	12		M8	18
200 MKR 16-4	4	16	15		M10	21
200 MKR 20-4	4	20	19		M10	25

Metallo duro - Hartmetallsorte - Carbide grade: MTE 30 TIALN

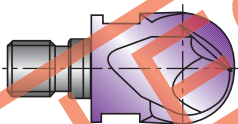

Art. **200 MKH**

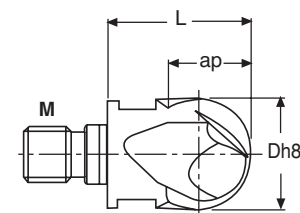

Fresa radiale 2 tagli per HSC-68HRC - Radien Fräskopf mit 2 Schneiden HSC-68HRC - Radial Carbide Milling Head 2 flutes HSC-68HRC

Codice d'ordine Order No. Bestell-Nr.	(mm) Dimensioni - Dimension - Abmessungen					
	Z	D	ap	R	M	L
200 MKH 8-2	2	8	10		M5	15
200 MKH 10-2	2	10	10		M6	16
200 MKH 13-2	2	13	12		M8	18
200 MKH 16-2	2	16	15		M10	21
200 MKH 20-2	2	20	19		M10	25

Metallo duro - Hartmetallsorte - Carbide grade: MTE 30 TIALN

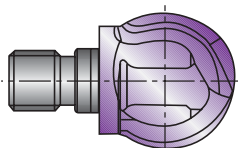

Art. **200 MKU**

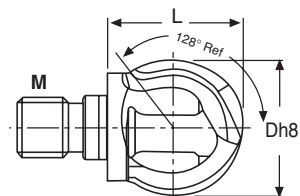

Fresa a palla 2 tagli - Kugel Fräskopf mit 2 Schneiden - Ball Carbide Milling Head 2 flutes

Codice d'ordine Order No. Bestell-Nr.	(mm) Dimensioni - Dimension - Abmessungen					
	Z	D	ap	C	M	L
200 MKU 10-2	2	10	7		M6	14
200 MKU 12-2	2	12	9,5		M6	14

Metallo duro - Hartmetallsorte - Carbide grade: MTE 30 TIALN

