

SpannGrip-Futter mit Durchgang Kurzkegelaufnahme

Through Bore Chuck Short Taper Flange

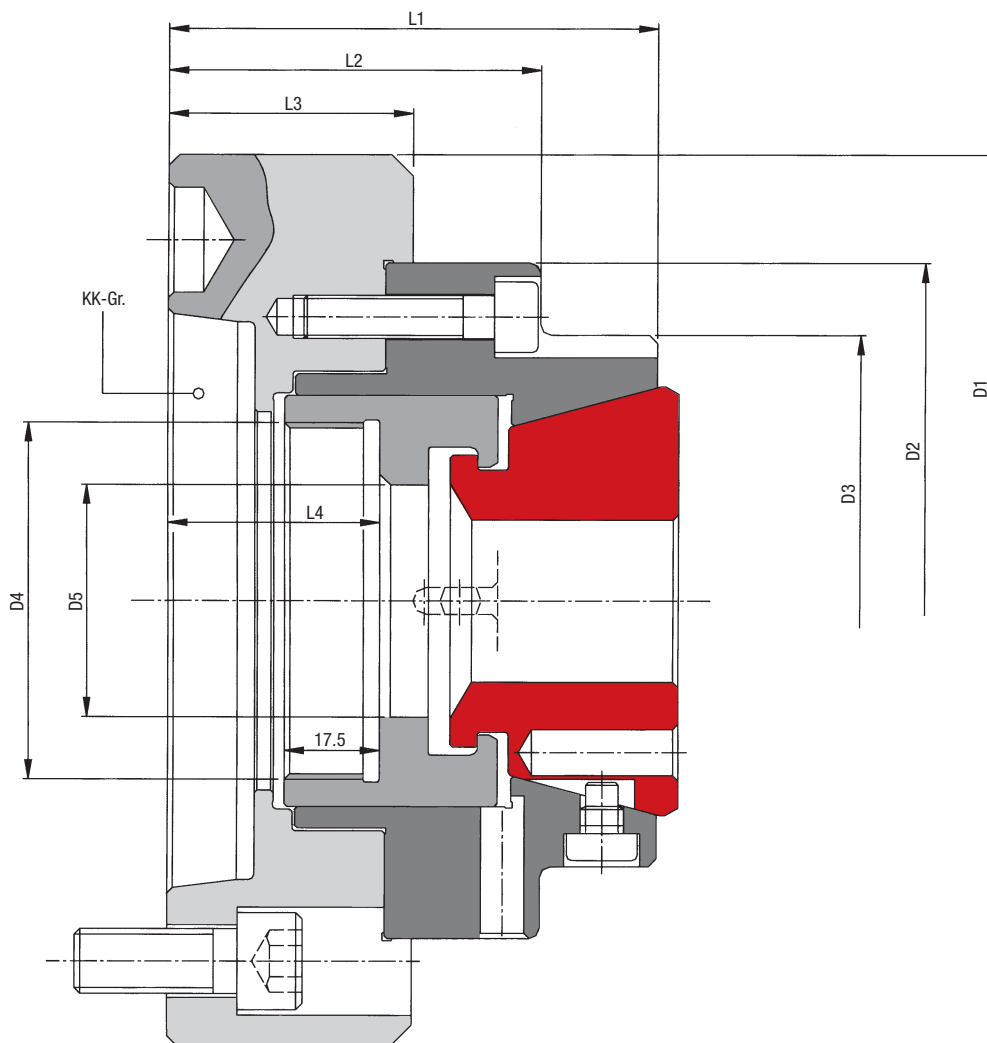

Bestell-Nr.	Ber.	Spannkopf Type	KK-Gr.	D1	D2	D3	D4	D5	L1	L2	L3	L4
SF-DK5-42	42	Gr. 42	KK5	140	124	98	M66x1,5	43	90	68,5	45	39
SF-DK6-42	42	Gr. 42	KK6	165	124	98	M66x1,5	43	90	68,5	45	39
SF-DK5-65	65	Gr. 65	KK5	150	140	120	M78x1,5	67	95	68,5	45	39
SF-DK6-65	65	Gr. 65	KK6	165	140	120	M78x1,5	67	95	68,5	45	39
SF-DK8-65	65	Gr. 65	KK8	210	140	120	M78x1,5	67	100	73,5	50	44

**SpannGrip-Futter mit Anschlag
mit Durchgang
Kurzkegelaufnahme**

**Endstop Chuck with
full passage
Short Taper Flange**

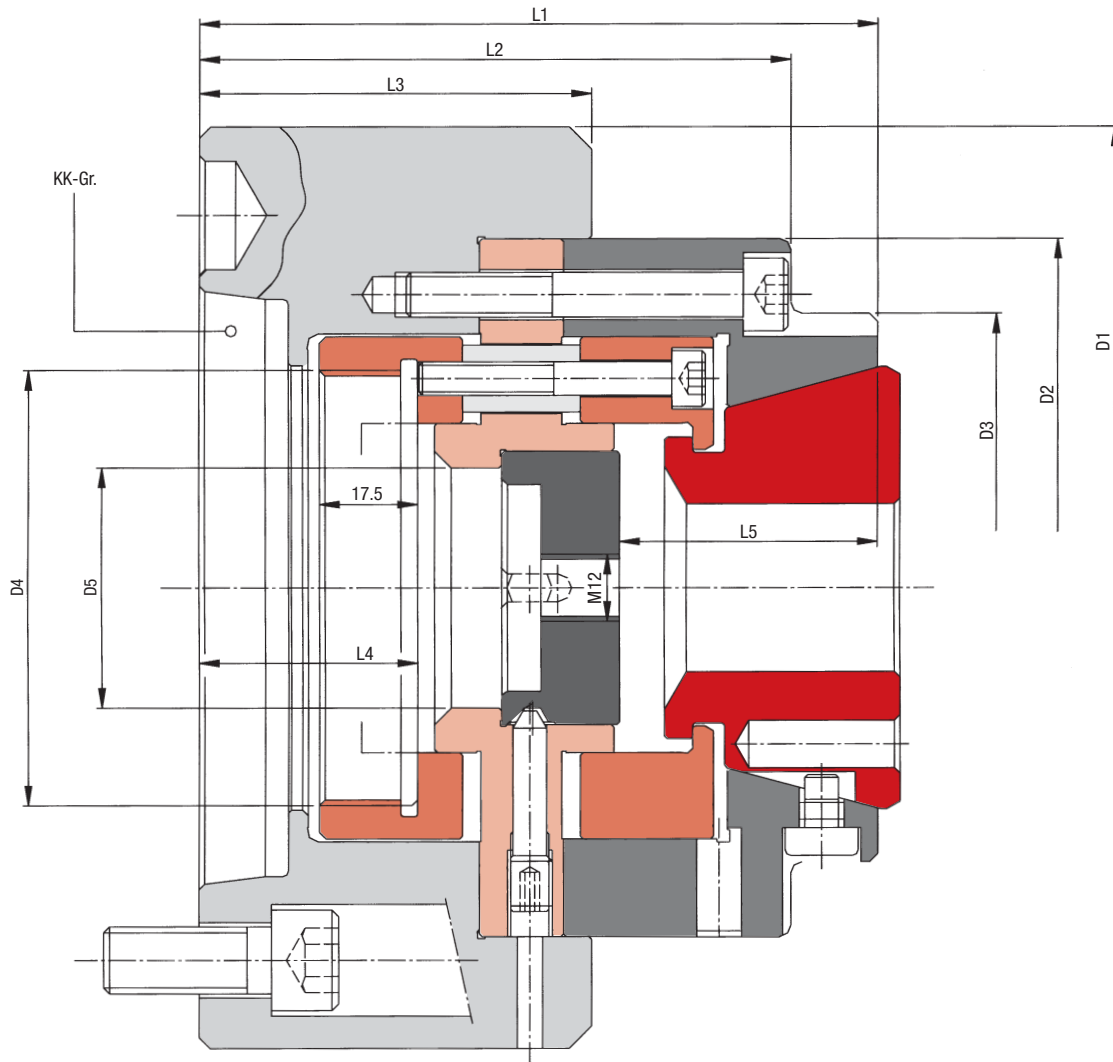

Bestell-Nr.	Spannkopf Type	KK-Gr.	D1	D2	D3	D4	D5	L1	L2	L3	L4	L5
SF-ADK5-42	Gr. 42	KK5	140	125	98	M78x1,5	43	121	105,5	70	39	46
SF-ADK6-42	Gr. 42	KK6	165	125	98	M78x1,5	43	121	105,5	70	39	46
SF-ADK5-65	Gr. 65	KK5	155	145	120	M78x1,5	66	130	111,5	70,5	39	55
SF-ADK6-65	Gr. 65	KK6	165	145	120	M78x1,5	66	130	111,5	70,5	39	55
SF-ADK8-65	Gr. 65	KK8	210	145	120	M78x1,5	66	135	116,5	75,5	44	55
SF-ADK6-100	Gr. 100	KK6	215	215	180	M95x2	107	177	162	72	55	99,5
SF-ADK8-100	Gr. 100	KK8	230	215	180	M115x2	107	178	157	51	50	99,5
SF-ADK11-100	Gr. 100	KK11	280	215	180	M112x2	102	205	184	76	47,5	99,5

SpannGrip-Futter mit Durchgang
zylindrische Aufnahme

Through Bore Chuck
Cylindrical Flange

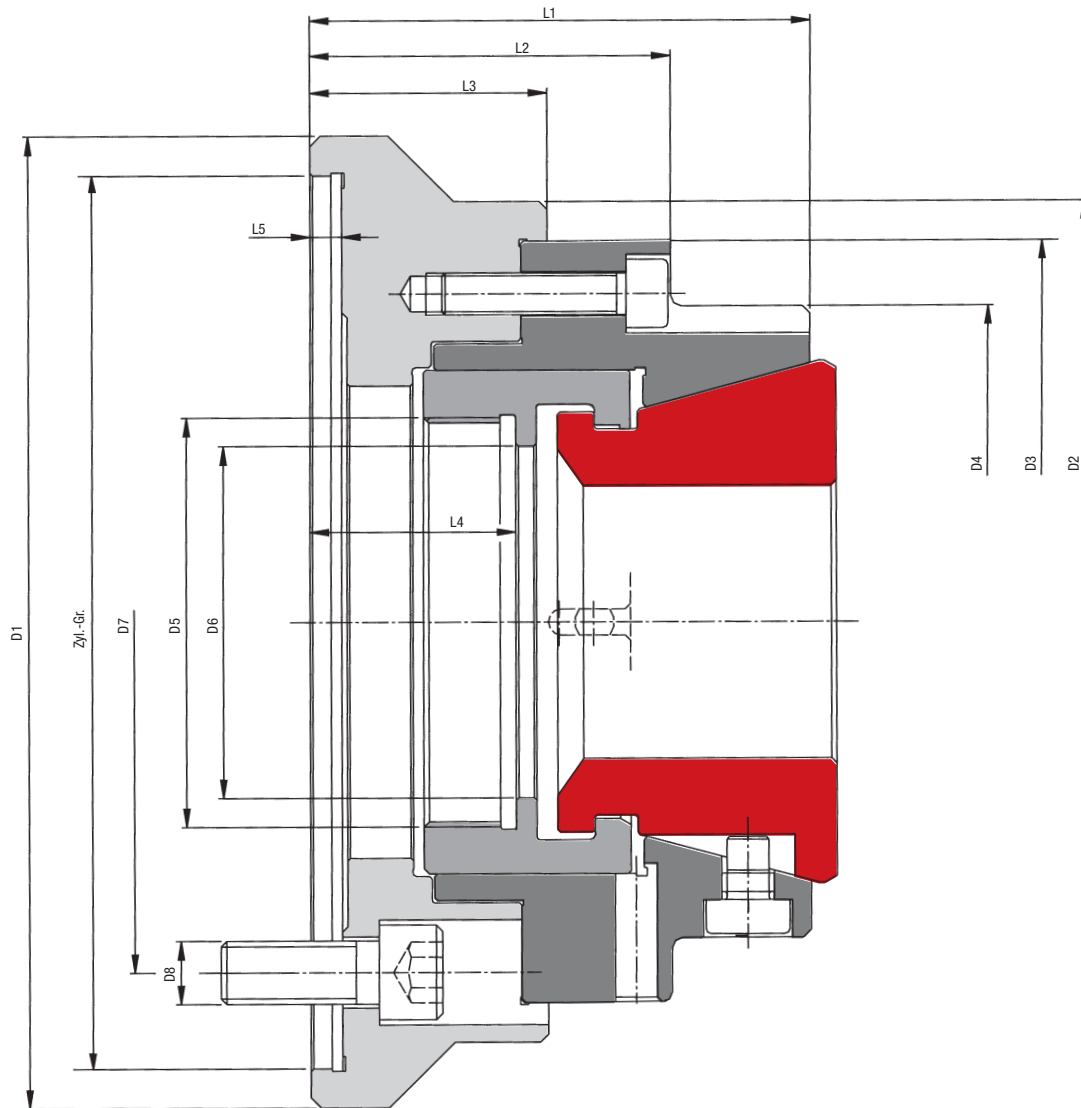

Bestell-Nr.	Spannk. Type	Zyl.-Gr.	D1	D2	D3	D4	D5	D6	D7	D8	L1	L2	L3	L4	L5
SF-DZ-42	42	140	150	150	125	98,3	M66x1,5	43	104,8	3xM10	90	68,5	45	39	6
SF-DZ-65	42	170	185	160	145	102,3	M66x1,5	67	133,4	6xM12	95	68,5	45	39	6

**SpannGrip-Futter mit Anschlag
mit Durchgang
zylindrische Aufnahme**

**Endstop Chuck with
full passage
Cylindrical Flange**

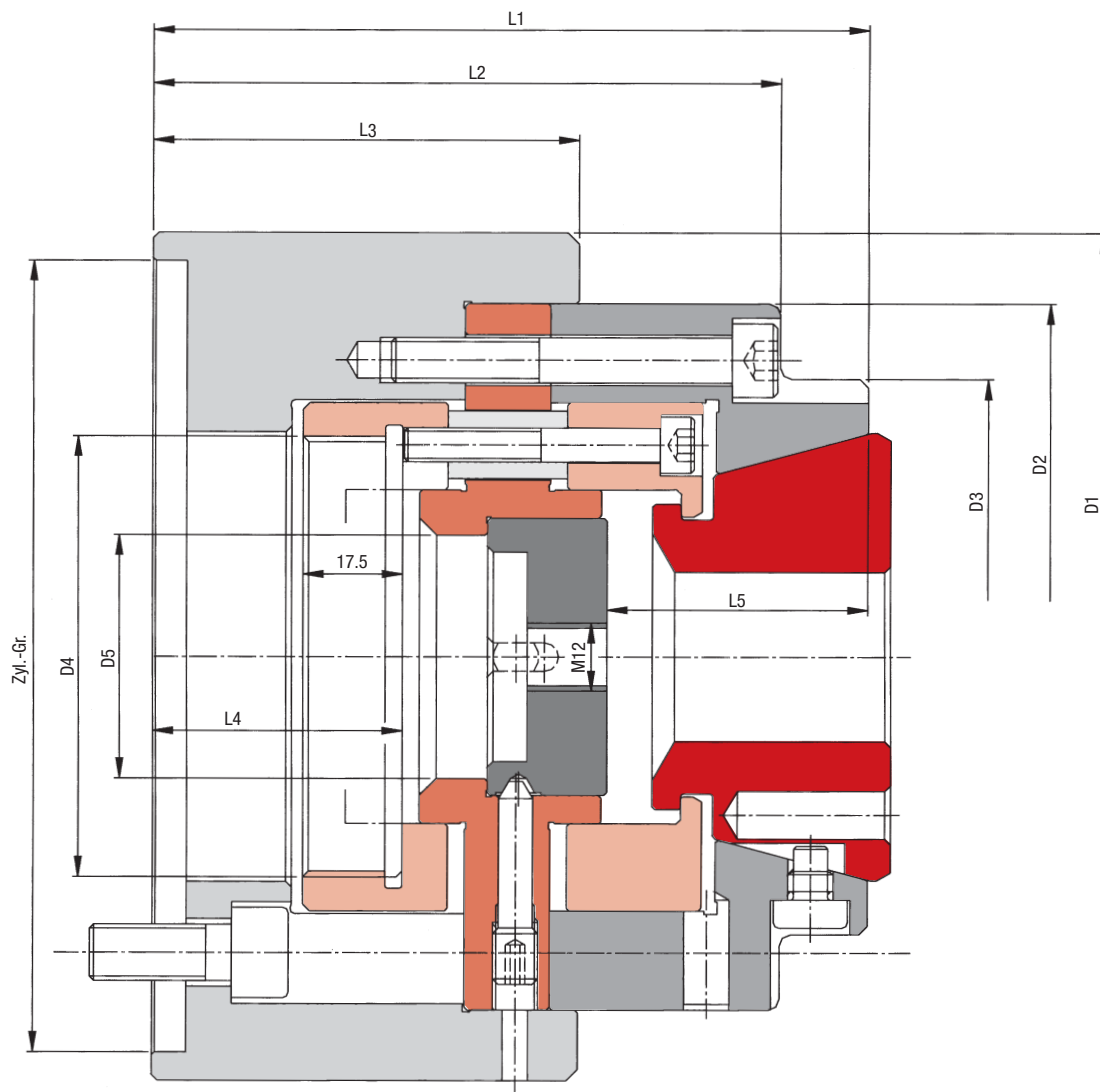

Bestell-Nr.	Spannkopf Type	Zyl.-Gr.	D1	D2	D3	D4	D5	L1	L2	L3	L4	L5
SF-ADZ-42	Gr. 42	Ø140	150	125	98	M78x1,5	43	126	110,5	75	44	46
SF-ADZ-65	Gr. 65	Ø170	185	145	120	M78x1,5	66	130	111,5	70,5	39	55
SF-ADZ-100	Gr. 100	Ø170	215	215	180	M95x2	102	165	144	72	37	99,5
SF-ADZ1-100	Gr. 100	Ø220	230	215	180	M115x2	102	165	144	72	37	99,5

SpannGrip-Futter mit Durchgang
ohne Längsversatz beim Spannen

Dead Length Chuck
Short Taper Flange

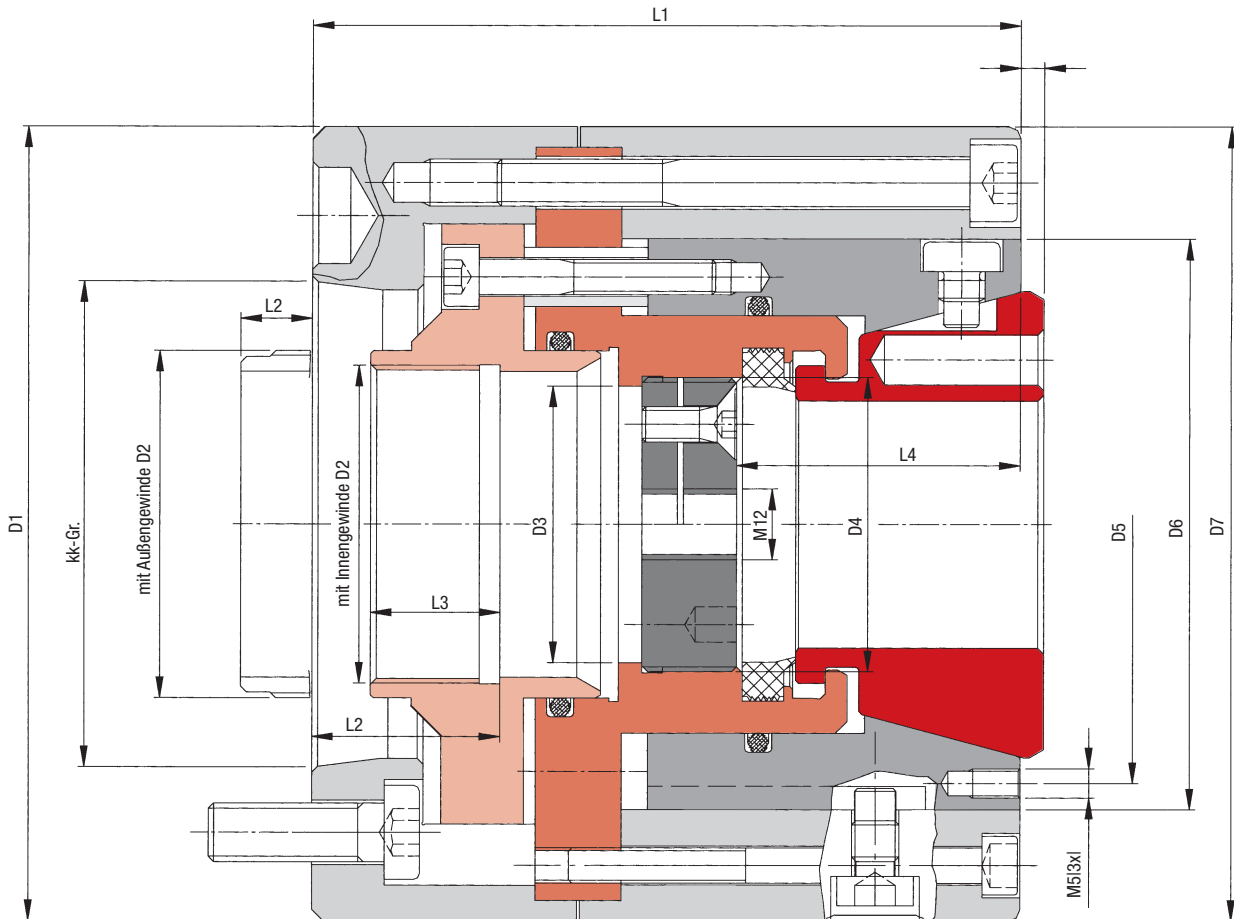

Bestell-Nr.	Spannkopf Type	KK-Gr.	D1	D2	D3	D4	D5	D6	D7	L1	L2	L3	L4
SF-DKL-42	Gr. 42	KK5	135	I M54x1,5	47	M50x1,5	88	97	135	120	32	22	48
SF-DKL1-42	Gr. 42	KK6	160	I M54x1,5	43	M50x1,5	88	97	135	120	32	22	48
SF-DKL-65	Gr. 65	KK6	161	A M74x1,5	67	M72x1,5	110	126	160	106	14	22	54,5
SF-DKL1-65	Gr. 65	KK6	160	I M78x1,5	67	M72x1,5	110	126	160	120	35	17,5	54,5
SF-DZL-42	Gr. 42	Z120	135	I M54x1,5	47	M50x1,5	88	97	-	120	32	22	48
SF-DZL-65	Gr. 65	Z170	185	I M78x1,5	67	M72x1,5	110	126	-	118	33	17,5	55

Sonstige Spannkopf-Futter in anderen Größen auf Anfrage.

Spannstöcke für SpannGrip Spannköpfe

Vices for Clamping Heads

Hydraulisch betätigt
Hydraulically operated

für SpannGrip Spannköpfe
For Clamping Heads

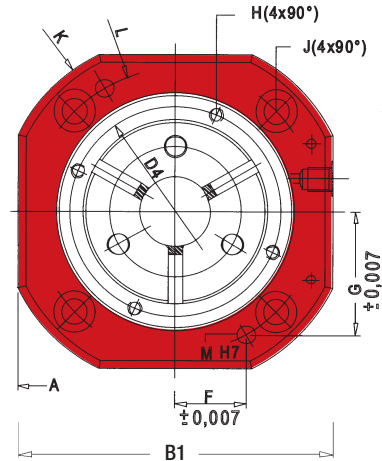
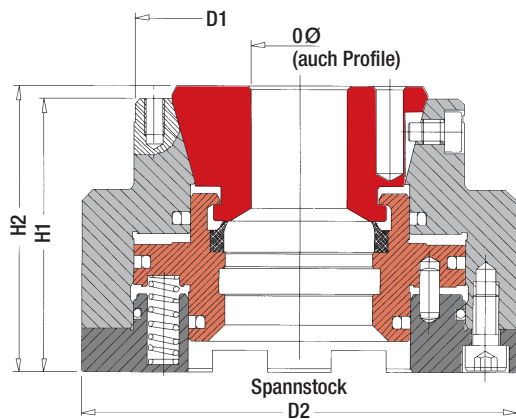

Bestell-Nr.	Für Spannköpfe	max Spann-Ø	D1	D2	H1	H2	B1
SPST-32	GR. 32	32	107 mm	152 mm	118 mm	124 mm	134 mm
SPST-42	GR. 42	42	125 mm	175 mm	120 mm	129 mm	154 mm
SPST-65	GR. 65	65	150 mm	200 mm	140 mm	149 mm	174 mm
SPST-80	GR. 80	80	160 mm	215 mm	140 mm	144 mm	186 mm
SPST-100	GR. 100	100	186 mm	232 mm	138 mm	138 mm	210 mm

Bestell-Nr.	Für Spannköpfe	max Druck p	Lösehub	Spannreserve
SPST-32	GR. 32	40 bar	3	2,5
SPST-42	GR. 42	40 bar	2,5	2
SPST-65	GR. 65	40 bar	2,5	2
SPST-80	GR. 80	40 bar	2,5	2
SPST-100	GR. 100	40 bar	5	2